

SIEMENS



SIMOTICS GP 1LE0001 低压交流异步电动机
SIMOTICS GP 1LE0001 Low-voltage Motors

2014.08

Answers for industry.



目录

Contents

总体介绍 Overview	3
参考标准 Reference standards	5
机械特性 Mechanical design	6
电气特性 Electrical design	14
变频应用 Converter fed application	18
订货号 Order No.	20
选型技术数据表 Technical data table	22
选件 Options	30
外形尺寸 Dimension drawings	34
认证 Certificates	39



总体介绍

SIMOTICS GP 1LE0001 系列电动机是铸铁机壳通用型全封闭自扇冷却式三相异步电动机，其防护等级为 IP55，1LE0001 系列电动机设计生产符合 ISO、IEC、GB 等相关标准的要求。采用 1LE0001 系列电动机，客户可以节能达 10% 之多！

1LE0001 系列电动机适用于连续工作制（S1）、恒转速或一定速度范围内的变频调速应用。

西门子 1LE0001 系列电动机技术特性

- 机座材料：灰铸铁；
- 标准颜色：石头灰（RAL 7030）；
- 额定功率：0.55kW~315kW（50Hz）
- 0.75kW 及以上的 2、4、6 极电动机达到 GB18613-2012 标准能效等级 3 级，且能满足 IEC 60034-30 标准中的 IE2 效率等级（50Hz）；
- 优化的紧凑型结构；
- 标准安装结构类型（符合 IEC 60034-7 标准规定）：IM B3、IM B5、IM B35 等；
- 所有的电动机设计防护等级为 IP55（IEC 60034-5）；
- FS¹⁾ 280 ~ 355 标配再润滑装置，FS¹⁾ 100 ~ 250 的作为选项；
- 对于 FS 100 ~ 355 范围电动机，可选择增强悬臂力设计；
- 电动机可选 PTC 或 PT100 热敏电阻或 KTY84-130 进行绕组保护；

¹⁾ FS，机座的英文（Frame Size）缩写。

Overview

SIMOTICS GP 1LE0001 series of 3 phase asynchronous motors (1LE0001 series motor) with cast iron housing is Totally Enclosed Fan Cooled (TEFC) with IP55 environmental protection, and applicable for general purpose use. These motors are designed and manufactured in accordance with ISO, IEC standards, GB standards. By switching to 1LE0001 series motor, customer can save energy up to 10 %!

The 1LE0001 series motor is designed for constant or adjustable speed with continuous duty operation (S1) over a speed range.

Features of Siemens 1LE0001 series

- Frame material: grey cast iron.
- Standard color: stone grey (RAL 7030)
- Rated power output: 0.55kW~315kW at 50Hz.
- Available in 2, 4, 6 pole motor (0.75kW and up) with efficiency grade 3. according to GB18613-2012 and efficiency class IE2 (50Hz) according to IEC 60034-30.
- Optimized compact style construction.
- Standard mounting construction according to IEC 60034-7: IM B3, IM B5, IM B35 and etc.
- All motors are designed to IP55 degree of protection (IEC 60034-5) .
- Re-greasing devices for FS¹⁾ 280 ~ 355 as standard, and for FS100 ~ 250 as option.
- Reinforced bearings for increased cantilever forces for FS100 ~ 355 as option.
- Winding protections with PTC, PT100 and KTY84-130 as option.

¹⁾ FS，Frame Size

- 接线盒标准位置处于机座顶端，进线孔处于右侧（从驱动端看），选项中接线盒位置和进线方向可变化；
- 绝缘系统按 155 (F) 温度等级设计，在额定输出和直接供电时按 130 (B) 温度等级使用；
- 电动机标准冷却方式为自扇冷却（IEC 60034-6 规定的 IC 411），可提供独立驱动风扇强制冷却；
- FS 80 ~ 90 电动机没有吊环；FS 100 ~ 315 电动机都有 2 个吊环，FS 355 电动机有 1 个吊环用于运输。

- Terminal box on top, and cable entry on right side (viewed from driven end). Variable location of connection boxes and cable entries as option.
- Insulation system is designed for temperature class 155 (F). At rated output with line-fed operation, the motors can be used in temperature class 130 (B).
- Self ventilated motors with radial-flow fans (cooling method IC 411 according to IEC 60034-6) as standard, forced air cool with external separately driven fans as option.
- FS 80 ~ 90 motor donot have eyebolt; FS 100 ~ 315 all motors have 2 eyebolts, and FS 355 motor have one eyebolt for transport.

运行环境

- 防护等级 IP55（IEC 60034-5）；
- 高度不超过海拔 1000 m（IEC 60034-1）；
- 允许的环境温度在 -20 °C ~ 40 °C（IEC 60034-1）；
- 所允许的相对湿度：
 - -20 °C ≤ T ≤ 20 °C：100 %
 - 20 °C < T ≤ 30 °C：95 %
 - 30 °C < T ≤ 40 °C：55 %

对于更高的环境温度、以及（或者）高于海拔 1000 m 的地点，电动机的额定功率换算系数为 k_{HT} 。所允许的功率值 (P_{adm})：

$$P_{adm} = P_{rated} \cdot k_{HT}$$

Environmental

- Degrees of motor protection IP55 (IEC 60034-5).
- Altitude shall not exceed 1000m above sea-level (IEC 60034-1).
- Allowed air temperature between -20 °C and 40 °C (IEC 60034-1).
- Permitted relative humidity:
 - -20 °C ≤ T ≤ 20 °C：100 %
 - 20 °C < T ≤ 30 °C：95 %
 - 30 °C < T ≤ 40 °C：55 %

For higher coolant temperatures and / or site altitudes higher than 1000 m above sea level, the specified motor output must be reduced by using the factor k_{HT} . The results in an admissible output (P_{adm}) of the motor:

$$P_{adm} = P_{rated} \cdot k_{HT}$$

对于不同高度和（或）不同环境温度的功率换算系数 k_{HT} Factor k_{HT} for different side altitudes and / or coolant temperature						
海拔高度 Site altitude above see level	对应海拔高度的环境温度 Site altitude above see level Coolant temperature					
	< 30 °C	30 ~ 40 °C	45 °C	50 °C	55 °C	60 °C
1000 m	1.07	1.00	0.96	0.92	0.87	0.82
1500 m	1.04	0.97	0.93	0.89	0.84	0.79
2000 m	1.00	0.94	0.90	0.86	0.82	0.77
2500 m	0.96	0.90	0.86	0.83	0.78	0.74
3000 m	0.92	0.86	0.82	0.79	0.75	0.70
3500 m	0.88	0.82	0.79	0.75	0.71	0.67
4000 m	0.82	0.77	0.74	0.71	0.67	0.63

参考标准

Reference standards

1LE0001 电动机符合下面的电气和机械标准:

The 1LE0001 complies with the following electrical and mechanical standards:

名称 Title	IEC 标准 IEC standard	中国国家标准 Chinese standard
旋转电动机定额和性能 Rotating electrical machines – Part 1: Rating and performance	IEC 60034-1	GB 755
旋转电动机损耗与效率确定的标准测试方法 Rotating electrical machines – Part 2-1: Standard methods for determining losses and efficiency from tests (excluding machines for traction vehicles)	IEC 60034-2	GB/T 1032
旋转电机整体结构的防护等级 (IP 代码) 分级 Rotating electrical machines – Part 5: Degrees of protection provided by the integral design of rotating electrical machines (IP code) - Classification	IEC 60034-5	GB/T 4942.1
旋转电动机冷却方法 Rotating electrical machines – Part 6: Methods of cooling (IC Code)	IEC 60034-6	GB/T 1993
旋转电动机结构型式、安装型式及接线盒位置的分类 (IM 代码) Rotating electrical machines – Part 7: Classification of types of construction, mounting arrangements and terminal box position (IM Code)	IEC 60034-7	GB/T 997
旋转电动机旋转电机线端标志与旋转方向 Rotating electrical machines – Part 8: Terminal markings and direction of rotation	IEC 60034-8	GB/T 1971
旋转电机噪声测定方法及限值 第 3 部分: 噪声限值 Rotating electrical machines – Part 9: Noise limits	IEC 60034-9	GB 10069.3
轴中心高为 56 mm 及以上电机的机械振动 振动的测量、评定及限值 Rotating electrical machines – Part 14: Mechanical vibration of certain machines with shaft heights 56 mm and higher – Measurement, evaluation and limits of vibration severity	IEC 60034-14	GB 10068
旋转电机尺寸和输出功率等级 第 1 部分: 机座号 56 ~ 400 和凸缘号 55 ~ 1080 Rotating electrical machines – Part 1: Frame numbers 56 to 400 and flange numbers 55 to 1080	IEC 60072-1	GB/T 4772.1
中小型旋转电机安全要求 Safety requirements of small and medium size rotating electrical machines		GB 14711
旋转电动机温升 Electrical insulation – Thermal classification	IEC 60085	GB/T 11021
电工电子产品自然环境条件 温度和湿度 Classification of environmental conditions Part 2-1: Environmental conditions appearing in nature – Temperature and humidity	IEC 60721-2-1	GB/T 4797.1
标准电压 Standard voltages	IEC 60038	GB/T 156

铭牌信息 Nameplate

1	3~Mot. 1LE0001-3BA2-J	3-3AA4-Z	355M	IMB3	IP55	LMH-1008 / 800003888994 / 001	26		
6	V	Hz	kW	A	EFF.	cos φ	r/min	EFF.Cl.	12
7	380/660 Δ/Y	50	220	390/225	95.0%	0.90	2980	IE2	11
8	440 Δ	60	246	375	95.4%	0.90	3580		10
14	BRG DE 6319 C3		BRG NDE 6319 C3		Th.Cl. 155(F)				13
15	GREASE:				IEC60034-30				25
16	Re-grease interval :2000h		Quantity: 40g		GB18613-2012 Eff.-Grade3				
	Q/321081 KJA001-2012				Net: 1600 kg				

3~Mot. 1LE0001-0EA0	2-1AA4	90S	IMB3	IP55	LMH-1008 / 800003888993 / 001		
V	Hz	kW	A	EFF.	cos φ	r/min	EFF.Cl.
220/380 Δ/Y	50	1.5	5.5/3.20	81.3 %	0.84	2890	IE2
440 Y	60	1.75	3.25	84.0 %	0.84	3470	
BRG DE 6205 2RZ C3		BRG NDE 6205 2RZ C3		Th.Cl. 155(F)			
				IEC60034-30			
				GB18613-2012 Eff.-Grade3			
Q/321081 KJA001-2012				Net: 34 kg			

- | | |
|-------------|---------------------------------------|
| 1 三相异步电动机 | Three-phase low-voltage motor |
| 2 订货号 | Order No. |
| 3 产品序列号 | Series number |
| 4 安装结构形式 | Type of construction |
| 5 防护等级 | Degree of protection |
| 6 额定电压 | Rated voltage and Winding connections |
| 7 频率 | Frequency [Hz] |
| 8 额定功率 | Rated output [kW] |
| 9 额定电流 | Rated current [A] |
| 10 效率 | Efficiency |
| 11 功率因数 | Power factor [cosφ] |
| 12 额定转速 | Rated speed |
| 13 热分级 | Thermal class |
| 14 驱动端轴承 | Bearing at the drive end |
| 15 润滑脂类型 | Grease type |
| 16 再润滑周期 | Re-grease interval |
| 17 执行标准 | Standards |
| 18 再加润滑脂的重量 | Quantity |
| 19 非驱动端轴承 | Bearing at the non-drive end |
| 20 中国国家标准 | GB standard |
| 21 净重 | Net weight |
| 22 中国能效等级 | GB efficiency grade |
| 23 机座号 | Frame size |
| 24 平衡方式 | Balance method |
| 25 IEC 标准 | IEC standard |
| 26 IEC 能效等级 | IEC efficiency class |

机械特性

接线盒

接线盒标准位置处于机座顶端，且自身可 $4 \times 90^\circ$ 旋转安装，从而使电缆可以从各个方向进入。所有接线盒都有两个进线孔，其中一个进线孔采用葛兰密封，另一个进线孔采用螺塞密封。



Mechanical design

Connection box

The connection box is located on the top of motor housing as standard, and can be rotated by $4 \times 90^\circ$ to allow for cable entry from each direction. All the connection box have 2 cable entries, one is sealed by the cable gland, and another sealed by screwed plug.



接线盒技术参数

机座号 Frame Size	主接线端子数 Number of main terminals	最多可容纳的 辅助端子数 Max. allowable auxiliary terminals	接线螺钉螺纹 Contact screw thread	引接线最大截面积 (mm ²) Max. connectable cross-section	外接电缆直径 (mm) Outer cable diameter (sealing range)	进线孔尺寸 (葛兰+螺塞) Cable entry size (Gland+Screwed plug)
80	6	12	M4	1.5	13 ~ 18	M25 × 1.5+M16 × 1.5
90	6	12		1.5		
100	6	12		4		
112	6	12		4		
132	6	12	M5	6	18 ~ 25	M32 × 1.5+M32 × 1.5
160	6	14		16		
180	6	14	M6	16	22 ~ 32	M40 × 1.5+M40 × 1.5
200	6	14 ¹⁾		25		
225	6	14 ¹⁾	M8	35	32 ~ 38	M50 × 1.5+M50 × 1.5
250	6	14 ¹⁾	M10	120		
280	6	14 ¹⁾		120	37 ~ 44	M63 × 1.5+M63 × 1.5
315	6	16 ¹⁾	M12	240		
355	6	24 ¹⁾	M16	240	44 ~ 57	M72 × 2+M72 × 2

注：¹⁾ 需要的辅助端子数若超过接线盒最多可容纳的辅助端子数时，须选择辅助接线盒（选件号：L97）

接线盒位置

接线盒除标准位置外，还可处于电动机机座的左侧或右侧。电动机接线盒位置可以在电动机订货号的第 16 位用数字表示出。

接线盒的位置是指从电动机驱动端来看的位置。

- 标配接线盒在顶部，电动机订货号的第 16 位数字为 4；
- 接线盒在右边，电动机订货号的第 16 位数字为 5；
- 接线盒在左边，电动机订货号的第 16 位数字为 6。

Connection boxes technical data

Note: ¹⁾ An auxiliary connection box (option code: L97) is required when the total number of auxiliary terminals exceeds the number of allowable terminals in main connection box.

Location of the connection box

Besides standard position, the connection box also can be on the right or left of motor housing. The position of terminal box can be indicated on the 16th digit of motor order code.

The position of connection box is described by viewed from drive end (DE).

- On top (Standard), 16th position of Motor Order No. digit 4.
- On RHS, 16th position of Motor Order No. digit 5.
- On LHS, 16th position of Motor Order No. digit 6.

当电动机的接线盒位置与其它部件冲突时，可以将接线盒从驱动端移到非驱动端（选件号：H08）。

If there is interfere between the connection box and other components, the connection box can be moved from the drive end (DE) to non-drive end (NDE) (Option code: H08).

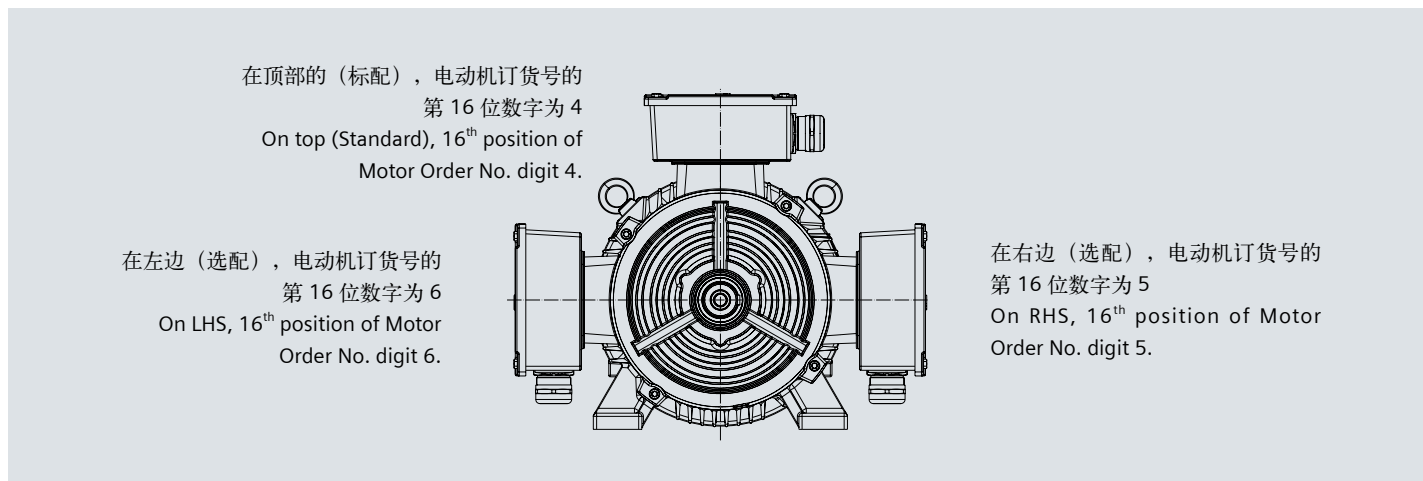

接线盒的进线孔

除非另作规定，否则进线孔的标准位置如下图所示。接线盒可以按照图示的位置旋转。

Cable entry on connection box

Unless stated, otherwise the cable entry is located in the standard position as show in the following illustration. The connection box can also be rotated such that the cable entry is located.

- 朝向驱动端
接线盒旋转 90°，进线口朝向驱动端，选件号为 R10。
对于 FS80 ~ 112 的带法兰（IM B5）电动机，只有接线盒在非驱动（选件号：H08）时，才可以选择进线孔朝向驱动端。
- 朝向非驱动端
接线盒旋转 90°，进线口朝向非驱动端，选件号为 R11。
- 朝向左侧（与标准方向相反）
接线盒旋转 180°，进线口位置相反，选件号为 R12。

- Towards the drive end (DE)
Rotation of connection box by 90°，entry from DE, Option code R10.
For flange motor (IM B5) from FS80 to FS100, only possible with connection box on NDE (Option code H08).
- Towards the non-drive end (NDE)
Rotation of connection box by 90°，entry from NDE, Option code R11.
- Towards the left side (opposite to Standard)
Rotation of connection box by 180°，entry from opposite end, Option code R12.

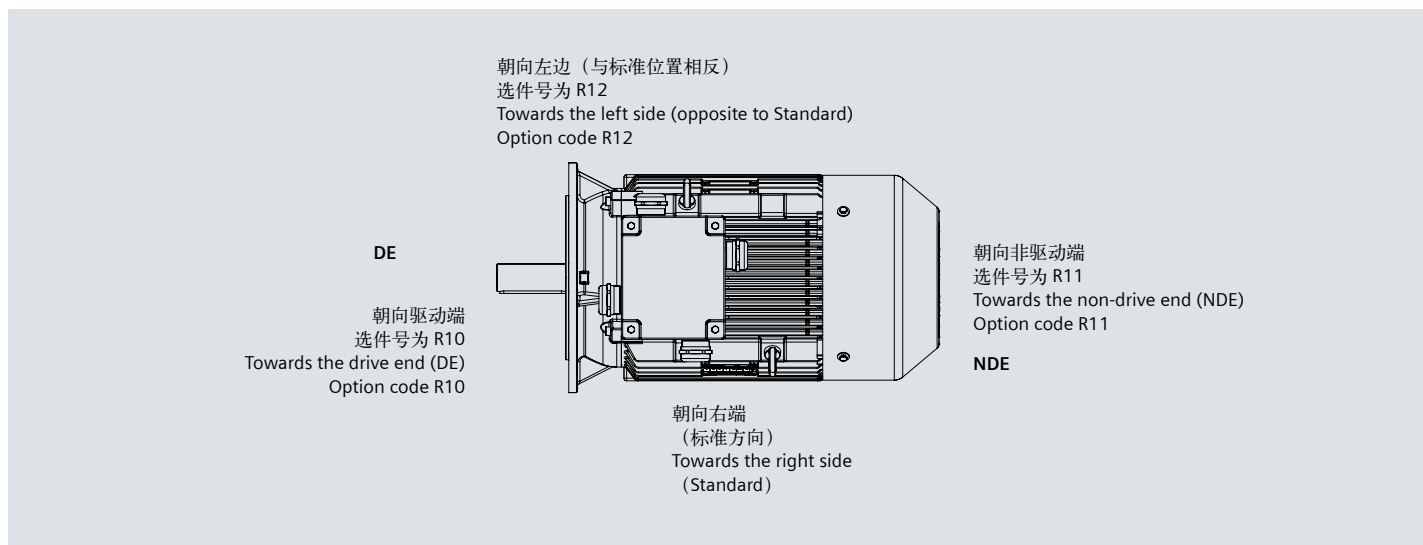

如果接线盒的位置改变时（如右侧或左侧），须要检查进线孔的位置是否方便进线。必要时，可以同时订购其它选件（R10，R11 和 R12）。

If the position of the connection box (connection box RHS or LHS) is changed, the position of the cable entry must be checked. If necessary, it can be ordered with the corresponding order codes (R10, R11 and R12).

安装结构型式 Construction and mounting type

结构型式 Construction type	机座带底脚，端盖无法兰 With feet and without flange on the end-shield (DE)					
安装型式 Mounting type	IM B3 FS 80 ~ 355	IM B6 FS 80 ~ 315	IM B7 FS 80 ~ 315	IM B8 FS 80 ~ 315	IM V5 ¹⁾ FS 80 ~ 315	IM V6 ²⁾ FS 80 ~ 315
示意图 Diagram						
电动机订货号第 14 位号上 对应的字母 Letter, position 14 th of Motor code	A	T	U	V	C	D
结构型式 Construction type	机座不带底脚，端盖有法兰 Without feet and with flange on the end-shield (DE)			机座带底脚，端盖有法兰 With feet and with flange on the end-shield (DE)		
安装型式 Mounting type	IM B5 FS 80 ~ 315	IM V1 ¹⁾ FS 80 ~ 355	IM V3 ²⁾ FS 80 ~ 315	IM B35 FS 80 ~ 355	IM V15 ¹⁾ FS 80 ~ 315	IM V35 ²⁾ FS 80 ~ 315
示意图 Diagram						
电动机订货号第 14 位号上 对应的字母 Letter, position 14 th of Motor code	F	G	H	J	W	Y
结构型式 Construction type	机座不带底脚，端盖有标准小法兰 Without feet and with C-flange on the end-shield (DE)			机座带底脚，端盖有标准小法兰 With feet and with C-flange on the end-shield (DE)		
安装型式 Mounting type	IM B14 FS 80 ~ 160	IM V18 ¹⁾ FS 80 ~ 160	IM V19 ²⁾ FS 80 ~ 160	IM B34 FS 80 ~ 160		
示意图 Diagram						
电动机订货号第 14 位号上 对应的字母 Letter, position 14 th of Motor code	K	M	L	N		

¹⁾ 室外使用时推荐使用护罩（选件号 H00）；

²⁾ 当户外安装时，推荐对电动机轴采取防护措施，避免水直接喷射到电动机轴上。

¹⁾ At outdoor application, the using of protective cover (Option code H00) is recommended

²⁾ At out door application the protection of shaft again jet-water is recommended

冷却与通风

所有电动机标配装有径流（离心）式冷却风扇，其冷却效能与电动机的旋转方向无关（冷却方法符合 IEC60034-6 标准的 IC411）。

对于某些应用，可以考虑配置独立驱动风扇，如，

- 电动机在低速运行时，推荐使用独立驱动风扇，从而使电动机得到有效利用；
- 电动机在明显高于额定同步转速的速度运行时，同样推荐选用独立驱动风扇，这样有助于降低电动机噪声。

独立驱动风扇的选件号为 F70。当安装独立驱动风扇时，电动机的长度将增加 ΔL 。

Cooling and ventilation

The 1LE0001 standard motors are fitted with an radial flow fan for cooling in accordance with IEC 60034-6 cooling method.

For some special application, separately driven fan should be considered to be configured.

- The use of a separately driven fan is recommended to increase motor utilization at low speed;
- When motor speed significantly higher than the synchronous speed, the separately fan is also recommended to be used. It can help reduce the motor noise.

The separately driven fan can be supplied already fitted, Option code F70. When the separately driven fan is mounted, the length of the motor increase by ΔL .

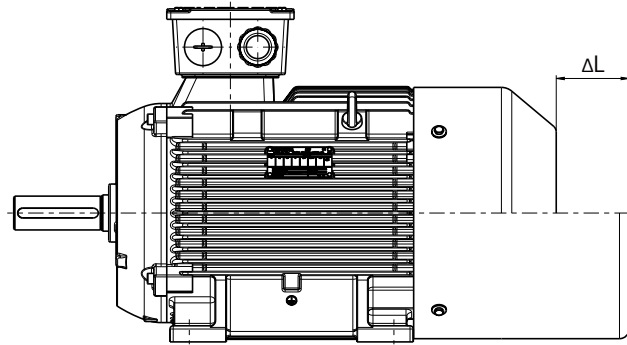

独立驱动风扇技术参数

Technical data for separately fan

对应电动机机座号 Motor frame size	电压 Voltage (V)	频率 Frequency (Hz)	功率 Rated output (W)	电流 Current (A)	转速 Speed (r/min)	ΔL (mm)
80	380 V	50	30	0.08	2800	60
90	380 V	50	30	0.08	2800	70
100	380 V	50	52	0.12	2800	80
112	380 V	50	52	0.12	2800	90
132	380 V	50	45	0.35	1400	75
160	380 V	50	45	0.35	1400	55
180	380 V	50	120	0.6	1400	35
200	380 V	50	120	0.6	1400	65
225	380 V	50	120	0.6	1400	60
250	380 V	50	230	1.0	1400	65
280	380 V	50	230	1.0	1400	110
315	380 V	50	370	1.1	1250	90
355	380 V	50	550	1.26	1350	100

轴承系统

1LE0001系列电动机标准配置深沟球轴承或角接触球轴承，这些轴承是密封的或可再润滑型的。

FS80 ~ 160 范围的 1LE0001 电动机驱动端与非驱动端轴承浮动；FS180 ~ 355 电动机驱动端轴承浮动，非驱动端轴承固定。

标准配置的轴承可以承受一定的悬臂力，关于悬臂力可以参见第 11 页“电动机轴驱动端允许的最大悬臂力”。当电动机轴端承受的悬臂力较大时，可以考虑选择增强悬臂力的轴承设计（选件号：L22）。

FS80 ~ 250 范围电动机标配不带再润滑装置；FS280 ~ 355 范围的电动机标配可再润滑轴承，并标配再润滑装置。如果需要，FS100 ~ 250 范围的电动机也可选用可再润滑轴承和再润滑装置（选件号：L23）。

轴承选配

机座号 Frame size	极数 Pole	标准配置 Standard design			增强悬臂力设计轴承（选件号：L22） Increased cantilever-bearing (Option code: L22)			再润滑轴承（选件号：L23） Re-greasing bearing (Option code: L23)	
		驱动端轴承 DE bearing	非驱动端轴承 (水平安装) NDE bearing (Horizontal mounting)	非驱动端轴承 (立式安装) NDE bearing (Vertical mounting)	驱动端轴承 DE bearing	非驱动端轴承 (水平安装) NDE bearing (Horizontal mounting)	非驱动端轴承 (立式安装) NDE bearing (Vertical mounting)	驱动端轴承 DE bearing	非驱动端轴承 NDE bearing
80	2, 4, 6	6204 2Z C3	6204 2Z C3	6204 2Z C3	—	—	—	—	—
90	2, 4, 6	6205 2Z C3	6205 2Z C3	6205 2Z C3	—	—	—	—	—
100	2, 4, 6	6206 2Z C3	6206 2Z C3	6206 2Z C3	6306 2Z C3	6206 2Z C3	6206 2Z C3	6206 C3	6206 C3
112	2, 4, 6	6206 2Z C3	6206 2Z C3	6206 2Z C3	6306 2Z C3	6206 2Z C3	6206 2Z C3	6206 C3	6206 C3
132	2, 4, 6, 8	6208 2Z C3	6208 2Z C3	6208 2Z C3	6308 2Z C3	6208 2Z C3	6208 2Z C3	6208 C3	6208 C3
160	2	6209 2Z C3	6209 2Z C3	6209 2Z C3	6309 2Z C3	6209 2Z C3	6209 2Z C3	6209 C3	6209 C3
	4, 6, 8								

Bearing system

1LE0001 series motors are supplied with the ball bearing as standard. These bearings are either of the sealed or regreaseable type.

For FS80 ~ 160, the floating bearings are assembled; for FS180 ~ 355, floating bearing at DE, and fixed bearing at NDE assembled.

The standard bearing can endure a maximum cantilever force, referred to page 11 - Permissible cantilever forces. If higher cantilever force on the shaft required, the increased cantilever bearing design (Option code: L22) should be considered.

As standard, FS80 ~ 250 motors are not with regreasing device, but FS280 ~ 355 motors with regreaseable bearing and regreasing device. If necessary, FS100 ~ 250 motor can be configured with regreaseable bearing and regreasing device (Option code: L23).

Bearing Assignment

机座号 Frame size	极数 Pole	标准配置 Standard design			增强悬臂力设计轴承 (选件号: L22) Increased cantilever-bearing (Option code: L22)			再润滑轴承 (选件号: L23) Re-greasing bearing (Option code: L23)	
		驱动端轴承 DE bearing	非驱动端轴承 (水平安装) NDE bearing (Horizontal mounting)	非驱动端轴承 (立式安装) NDE bearing (Vertical mounting)	驱动端轴承 DE bearing	非驱动端轴承 (水平安装) NDE bearing (Horizontal mounting)	非驱动端轴承 (立式安装) NDE bearing (Vertical mounting)	驱动端轴承 DE bearing	非驱动端轴承 NDE bearing
180	2	6210 Z C3	6210 Z C3	6210 Z C3	NU210	6210 Z C3	6210 Z C3	6210 C3	6210 C3
	4, 6, 8								
200	2	6212 Z C3	6212 Z C3	6212 Z C3	NU212	6212 Z C3	6212 Z C3	6212 C3	6212 C3
	4, 6, 8								
225	2	6213 Z C3	6213 Z C3	6213 Z C3	NU213	6213 Z C3	6213 Z C3	6213 C3	6213 C3
	4, 6, 8								
250	2	6215 C3	6215 C3	7215 AC	NU215	6215 C3	O.R.	6215 C3	6215 C3
	4, 6, 8								
280	2	6317 C3	6317 C3	7317 AC	NU317	6317 C3	O.R.	<input type="checkbox"/>	<input type="checkbox"/>
	4, 6, 8	6317 C3	6317 C3		NU317	6317 C3		<input type="checkbox"/>	<input type="checkbox"/>
315	2	6319 C3	6319 C3	7319 AC	NU319	6319 C3	O.R.	<input type="checkbox"/>	<input type="checkbox"/>
	4, 6, 8	6319 C3	6319 C3		NU319	6319 C3		<input type="checkbox"/>	<input type="checkbox"/>
355	2	6319 C3	6319 C3	7319 AC	NU319	6319 C3	O.R.	<input type="checkbox"/>	<input type="checkbox"/>
	4, 6, 8	6322 C3	6322 C3	7322 AC	NU322	6322 C3	O.R.	<input type="checkbox"/>	<input type="checkbox"/>

注:
DE 驱动端
NDE 非驱动端
- 不能满足
 标准配置
O.R. 须要特殊询价

Note:
DE Driven end
NDE Non driven end
- Not possible
 Standard
O.R. Possible on request

轴承寿命 (标称寿命)

轴承的标称额定寿命可根据 ISO 281 标准规定的标准计算程序计算出来的。如果电动机在该样本中所规定条件下运行, 90 % 甚至更高比例的轴承的运行时间可达到标称寿命。通常, 轴承的使用寿命取决于轴承规格、轴承载荷、运行条件、转速以及润滑脂寿命。

当电动机水平安装, 且不受轴向力的情况下, 电动机的轴承寿命至少能够达到 40,000 小时。在承受最大容许载荷的情况下, 其寿命也至少有 20,000 小时, 这里所说的轴承寿命, 指的都是电动机在 50 Hz 下正常运行的情况。

当电动机在非正常的条件下运行时, 轴承的寿命会缩短。如下面几种情况:

- 当电动机的运行速度高于额定速度时, 由于电动机的振动增大, 使得轴承受到额外的径向力和轴向力, 导致其寿命减少;
- 当环境或设备等因素引起电动机振动加大时, 同样轴承也会因此受到额外的径向力和轴向力, 而导致其寿命减少;
- 当环境温度每升高 10°C, 润滑脂寿命以及再润滑时间缩短一半。

润滑脂寿命和再润滑周期

对于不可再润滑的轴承, 其润滑脂寿命与轴承寿命相当。但是, 这只能是在电机严格按照本样本中规定的技术数据运行。

对于以规定间隔再润滑的电机, 轴承寿命可以延长, 从而补偿不利因素, 诸如温度、安装条件、转速、轴承规格和机械载荷造成的影响。

Bearing life time (nominal lifetime)

The nominal bearing lifetime is defined according standardized calculation procedures (ISO 281) and is reached or even exceeded for 90% of the bearings when the motors are operated in compliance with the data provide in the catalog. Generally, the bearing lifetime is defined by the bearing size, the bearing load, the operating condition, the speed and the grease lifetime.

The bearing lifetime of motors with horizontal type of construction is at least 40,000 hours if there is no additional axial loading at the coupling output and at least 20,000 hours with the maximum admissible loads. This assumes that the motor is operated at 50Hz.

When the motor runs outside of normal conditions, the bearing life will be reduced, such as the following conditions.

- When 1LE0001 motor runs beyond the rated speed, the increase of motor vibration will result in the extra radial and axial force on bearing. This will reduce the life of bearing;
- When the motor vibration increase due to the environment or other equipment, the bearing also will endure more radial and axial force. This also will reduce the life of bearing;
- If the coolant temperature is increased by 10 °C, the grease lifetime and regreasing interval is halved.

Grease life and re-greasing interval

For permanent lubrication, the bearing grease lifetime is matched to the bearing lifetime. This can, however, only be achieved if the motor is operated in accordance with the catalog specifications.

For motors which can be regreased at defined regreasing intervals, the bearing lifetime can be extended and/or unfavorable factors such as temperature, mounting conditions, speed, bearing size and mechanical load can be compensated.

润滑脂寿命和再润滑周期（电动机水平安装）

Grease life (Horizontal installation)

机座号 Frame size	极数 Poles	润滑脂寿命 Grease lifetime up to CT 40 °C ¹⁾
持久润滑型轴承的润滑脂 Grease for permanent lubrication bearing		
80 ~ 250	2, 4, 6, 8	20000 或 (or) 40000 ²⁾
可再润滑型轴承的润滑脂 Grease for regreasable bearing		
100 ~ 160	2, 4, 6, 8	8000 小时 (h)
180 ~ 250	2	4000 小时 (h)
180 ~ 250	4, 6, 8	8000 小时 (h)
280 ~ 315	2	3000 小时 (h)
280 ~ 315	4, 6, 8	5000 小时 (h)
355	2	2000 小时 (h)
355	4, 6, 8	4000 小时 (h)

注:

- ¹⁾ 当环境温度每升高 10 °C，润滑脂寿命以及再润滑时间缩短一半。
- ²⁾ 在环境温度 25 度下，40000 小时适用于电动机水平安装，且轴不受额外的轴向力影响；

Note:

- ¹⁾ If the coolant temperature is increased by 10 K, the grease lifetime and regreasing interval are halved.
- ²⁾ 40000 h apply to horizontally installed motors with coupling output without additional axial loads.

电动机轴驱动端允许的最大悬臂力

Permissible cantilever forces on DE shaft

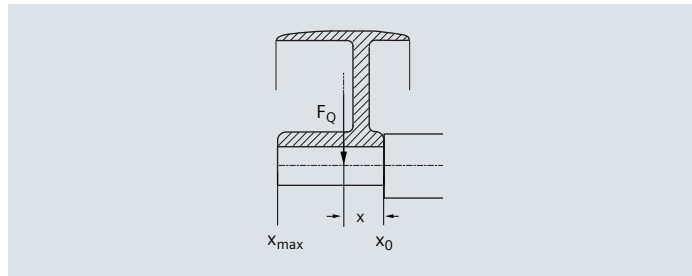

为了计算径向负载的最大悬臂力，据轴肩处的悬臂力 F_Q (N) 必须位于轴伸端以内，（长度为 x ）。长度 x [mm] 是距离轴肩的距离。长度最长为 x_{max} ，与轴伸长度相同。总的悬臂力 F_Q 使用以下公式计算。

$$F_Q = c \cdot F_U$$

预紧力系数 c 是从皮带制造商那得到的经验数值，下面的估算值可以应用。

- 对于一般扁平的皮带， $c = 2$ ；
- 对于 V 型皮带， $c = 2 \sim 2.5$ ；
- 对于特殊的皮带（取决于皮带类型和负载）， $c = 2 \sim 2.5$ 。

计算切向力 F_U (N) 使用下列公式：

$$F_U = 2 \cdot 10^7 \frac{P}{n \times D}$$

- F_U 切向力 (N)
 P 额定功率 (kW)
 n 额定转速
 D 滑轮直径 (mm)

In order to calculate the admissible cantilever forces for a radial load, the line of force (i.e. the centerline of the pulley) of the cantilever force F_Q (N) must lie within the free shaft extension (dimension x). Dimension x [mm] is the distance between the point of application of force F_Q and the shaft shoulder. Dimension x_{max} corresponds to the length of the shaft extension. Total cantilever force is calculated using the following equation.

$$F_Q = c \cdot F_U$$

The pre-tension factor c is a value gained from experience from the belt manufacturer. The following approximate value can be assumed.

- For normal flat leather belts with an idler pulley, $c = 2$.
- For v-belts, $c = 2$ to 2.5.
- For special synthetic belts (depending on the type and load), $c = 2$ to 2.5.

The circumferential force F_U (N) is calculated using the following equation.

$$F_U = 2 \cdot 10^7 \frac{P}{n \times D}$$

- F_U circumferential force in N
 P rated motor power (transmitted power) in kW
 n rated motor speed
 D pulleys in mm.

假设电动机不受任何轴向力，下面的表格中列出了允许的径向悬臂力值（单位：牛顿）。

The table below contains the permissible Radial Force values in Newtons with the assumption of zero axial forces.

标准电机最大悬臂力 Admissible cantilever forces for standard version			
机座号 Frame size	极数 Number of poles	悬臂力范围 ¹⁾ Admissible cantilever force ¹⁾	
		for x_0 N	for x_{max} N
80M	2	620	510
	4	790	640
	6	910	740
90S 90L	2	700	560
	4	880	720
	6	1,020	820
100L	2	980	790
	4	1,230	990
	6	1,420	1,140
112M	2	980	790
	4	1,230	990
	6	1,420	1,140
132S 132M	2	1,440	1,120
	4	1,820	1,420
	6	2,080	1,630
160M 160L	2	2,300	1,800
	4	1,560	1,240
	6	1,970	1,570
180M 180L	2	2,260	1,800
	4	2,500	1,980
	6	1,820	1,470
200L	2	2,300	1,900
	4	2,630	2,150
	6	4,800	3,880
225S 225M	2	2,650	2,230
	4	3,350	2,800
	6	3,850	3,230
250M	2	6,520	5,380
	4	3,000	2,540
	6	3,700	3,000
280S 280M	2	4,250	3,470
	4	7,300	5,790
	6	3,150	2,620
315S 315M 315L	2	3,950	3,280
	4	4,600	3,820
	6	8,110	6,620
355M 355L	2	6,600	5,550
	4	8,300	6,950
	6	9,650	8,120
	2	11,600	9,800
	4	7,100	6,200
	6	8,700	7,250
	2	10,000	8,500
	4	14,300	10,400
	6	6,800	6,000
	2	11,500	10,000
	4	13,200	11,600
	6	19,000	15,600

增强悬臂力的轴向设计（编号 L22） Bearing design for increased cantilever forces Order code L22			
机座号 Frame size	极数 Number of poles	悬臂力范围 ¹⁾ Admissible cantilever force ¹⁾	
		for x_0 N	for x_{max} N
80M	2	— ²⁾	— ²⁾
	4	— ²⁾	— ²⁾
	6	— ²⁾	— ²⁾
90S 90L	2	— ²⁾	— ²⁾
	4	— ²⁾	— ²⁾
	6	— ²⁾	— ²⁾
100L	2	1,480	1,220
	4	1,870	1,540
	6	2,140	1,720
112M	2	1,480	1,220
	4	1,870	1,540
	6	2,140	1,720
132S 132M	2	2,100	1,700
	4	2,720	2,170
	6	3,100	2,420
160M 160L	2	3,400	2,700
	4	2,650	2,120
	6	3,300	2,600
180M 180L	2	3,750	2,900
	4	3,750	2,900
	6	3,300	2,700
200L	2	4,200	3,400
	4	4,750	3,900
	6	6,950	4,050
225S 225M	2	5,000	4,200
	4	6,330	5,320
	6	7,250	6,080
250M	2	10,100	7,400
	4	5,650	4,800
	6	6,950	5,600
280S 280M	2	7,900	6,500
	4	11,300	7,350
	6	6,700	5,600
315S 315M 315L	2	8,500	7,000
	4	9,500	7,800
	6	12,800	10,500
355M 355L	2	11,500	9,500
	4	17,000	14,000
	6	20,000	17,000
	2	22,000	17,500
	4	14,600	12,300
	6	20,000	16,500
	2	23,000	19,000
	4	25,000	20,000
	6	15,800	14,000
	2	22,000	19,000
	4	25,000	22,000
	6	29,000	26,000

¹⁾ 对于安装型式为 IM B6, IM B7, IM B8, IM V5, IM V6 时，在电动机底脚的支撑力足够的情况下，皮带张力垂直于或指向安装平面。采用底脚安装的电动机两个底脚必须牢固

²⁾ 增强悬臂力型只适用于 FS100 ~ 355

¹⁾ It should be considered that for types of construction IM B6, IM B7, IM B8, IMV5 and IM V6 the belt tension is only permitted to act parallel to the mounting plane or towards the mounting plane and the feet must be supported. Both feet must be secured for foot-mounting types of construction

²⁾ Reinforced version only from FS100 ~ 355

噪声

噪声值

噪声值根据 DIN EN ISO 1680 标准在噪音室测得。表面声压级噪声 L_{pfa} 计算表示单位为 dB (A)。声压级噪声的空间平均值是在其测量面上测得的。测量面是距离电动机表面一立方米的地方。声功率级噪声用 L_{WA} 来表示，单位为 dB (A)。下面给出噪声值仅适用于电动机在 50 Hz 电源供电空载运行时的情况，容差为 +3 dB。当在 60 Hz 电源下空载运行时，偏差值大约为 +4 dB。

Noise levels

Noise levels for mains-fed operation

The noise levels are measured in accordance with DIN EN ISO 1680 in a dead room. It is specified as the A-valued measuring-surface sound pressure level L_{pfa} in dB (A). This is the spatial mean value of the sound pressure levels measured on the measuring surface. The measuring surface is a cube 1 m away from the motor surface. The sound power level is also specified as L_{WA} in dB (A). The following specified values are only valid for no load at 50 Hz with no load, and the tolerance is +3 dB. While motor operating 60 Hz with no load, the values are approximately +4 dB (A) higher.

功率 Output (kW)	同步转速 synchronous speed (r/min)			
	L_{pfa} / L_{WA} (dB (A))			
	3000 (2 极 poles)	1500 (4 极 poles)	1000 (6 极 poles)	750 (8 极 poles)
0.55	—	45 / 57	44 / 56	—
0.75	53 / 65	45 / 57	48 / 60	—
1.1	53 / 65	47 / 59	48 / 60	—
1.5	60 / 72	47 / 59	52 / 64	—
2.2	60 / 72	55 / 67	54 / 66	51 / 64
3	62 / 74	55 / 67	56 / 69	51 / 64
4	63 / 75	55 / 67	56 / 69	55 / 68
5.5	66 / 79	57 / 70	56 / 69	55 / 68
7.5	66 / 79	57 / 70	60 / 73	55 / 68
11	67 / 80	60 / 73	60 / 73	56 / 69
15	67 / 80	60 / 73	61 / 74	58 / 71
18.5	67 / 80	61 / 74	65 / 78	59 / 72
22	69 / 82	61 / 74	65 / 78	59 / 72
30	71 / 84	63 / 76	65 / 79	59 / 72
37	71 / 84	63 / 77	65 / 79	59 / 72
45	74 / 88	63 / 77	65 / 79	59 / 72
55	74 / 88	64 / 78	65 / 79	69 / 82
75	74 / 88	66 / 80	66 / 80	69 / 82
90	76 / 90	66 / 80	66 / 80	69 / 82
110	78 / 92	69 / 83	68 / 82	69 / 82
132	78 / 92	69 / 83	68 / 83	77 / 90
160	81 / 95	69 / 83	72 / 87	77 / 90
185	81 / 95	74 / 88	75 / 90	77 / 90
200	81 / 95	74 / 88	75 / 90	77 / 90
220	86 / 101	82 / 97	75 / 90	—
250	86 / 101	82 / 97	75 / 90	—
280	88 / 103	85 / 100	—	—
315	88 / 103	85 / 100	—	—

L_{pfa} – 声压级

L_{WA} – 声功率级

L_{pfa} – sound pressure level

L_{WA} – sound power level

振动

所有电动机转子都使用半键按照 A 级（标准）振动等级进行动态平衡。电动机在空载时测得振动速度有效值不超过下表中的 A 级所列值。

Vibration

1LE0001 rotors are dynamically balanced to severity grade A using a half key.

Table below contains the effective vibration values for unloaded motors.

振动等级 Vibration grade	机座号 Frame size (mm)	$56 \leq FS \leq 132$	$160 \leq FS \leq 280$	$280 < FS \leq 355$
A	安装方式 Mounting	Vibration velocity 振动速度 (mm/s)	Vibration velocity 振动速度 (mm/s)	Vibration velocity 振动速度 (mm/s)
	自由悬置 Free suspension	1.6	2.2	2.8
	刚性安装 Rigid mounting	1.3	1.8	2.3
B	自由悬置 Free suspension	0.7	1.1	1.8
	刚性安装 Rigid mounting	—	0.9	1.5

电气特性

Electrical design

额定输出

1LE0001 电动机的额定功率是指电动机在连续运行的情况下 S1 (IEC 60034-1)，此时周围环境温度为 -20 °C ~ 40 °C，海拔高度不超过 1000 m。

Rated Output

1LE0001 motors rated output powers means that the motor runs under continuous duty S1 (IEC 60034 - 1) operation when operated at ambient temperature from -20 °C to 40 °C and at altitudes of up to 1000 m over sea.

电压、频率

IEC 60034-1 将电压和频率的偏差分为 A 类 (电压偏差 ±5%，频率偏差 ±2%) 和 B 类 (电压偏差 ±10%，频率偏差 +3% / -5%)。电动机均能够在 A 类和 B 类提供额定转矩。在 A 类中，温度比正常运行下温度大约提升 10 K。

Voltage and Frequency

IEC 60034-1 differentiates between Category A (combination of voltage deviation ±5 % and frequency deviation ±2 %) and Category B (combination of voltage deviation ±10 % and frequency deviation +3 % / -5 %) for voltage and frequency fluctuations. The motors can supply their rated torque in both Category A and B. In Category A, the temperature rise is approximately 10 K higher than during normal operation.

标准 Standard	类别 Category	类别 Category
60034 - 1	A	B
电压偏差 Voltage deviation	±5 %	±10 %
频率偏差 Frequency deviation	±2 %	+3 % / -5 %
根据标准，不推荐电动机在 B 类情况下长时间运行 According to the standard, longer operation is not recommended for Category B.		

电气数据公差

- 效率 η
 $P_{\text{rated}} \leq 150 \text{ kW}: -0.15 \times (1 - \eta)$
 $P_{\text{rated}} > 150 \text{ kW}: -0.10 \times (1 - \eta)$
 效率 η 为小于 1 的值
- 功率因数: $(1 - \cos \phi) / 6$
 最小绝对值: 0.02
 最大绝对值: 0.07
- 转差率: ±20% (电动机的偏差 < 1 kW ± 30% 时是允许的)
- 堵转电流: +20%
- 堵转转矩: -15% ~ +25%
- 最大转矩: -10%
- 转动惯量: ±10%

Tolerance for electrical data

- Efficiency η at
 $P_{\text{rated}} \leq 150 \text{ kW}: -0.15 \times (1 - \eta)$
 $P_{\text{rated}} > 150 \text{ kW}: -0.10 \times (1 - \eta)$
 With η being a decimal number
- Power factor - $(1 - \cos \phi) / 6$
 Minimum absolute value: 0.02
 Maximum absolute value: 0.07
- Slip ±20% (for motors < 1 kW ± 30% is admissible)
- Locked-rotor current +20%
- Locked-rotor torque -15% to +25%
- Breakdown torque -10%
- Moment of inertia ±10%

过载倍数

根据 IEC60034 标准要求，1LE0001 系列电动机能够在额定电压和频率下承受 1.5 倍的额定电流达 2 分钟。

Overload times

According to IEC60034, 1LE0001 series motors are designed to withstand overload capacity of 1.5 times rated current for 2 minutes at rated voltage and frequency.

绝缘系统

1LE0001 电动机绝缘系统具有可靠性、耐用性好和寿命长、耐冲击能力强的特点。

1LE0001 系列电动机标准设计温度等级为 155 (F)。当 1LE0 电动机直接供电，且输出额定功率时，其绝缘系统按 130 (B) 温度等级使用。

电动机保护

电动机过热保护

电动机热保护是指将温度保护传感器或温度检测传感器嵌入电动机定子绕组或其他适当的地方，从而使其不会因为过热而受到破坏。

不同的电动机热保护方式可以在 1LE0001 电动机订货号的第 15 位采用不同的字母或者选项号来表示。下面是电动机的绕组保护和轴承保护的几种保护方式。

绕组保护

■ PTC 热敏电阻温度保护

目前，最常用的电动机绕组过热保护方式是采用在电动机绕组中安装 PTC 热敏电阻进行保护。由于热敏电阻的热容量较低以及其在绕组间优良的热传导特性，绕组温度可被准确的监控。当达到极限温度时（标称跳闸温度），PTC 热敏电阻阻值会出现一个阶跃变化。这一变化被跳闸装置捕捉后，即可断开辅助回路。

PTC 热敏电阻本身不能耐受大电流和高电压。否则会导致半导体器件损坏。PTC 热敏电阻和跳闸装置的开关滞后效应小，因此可以实现快速重起。对于重载起动、起动频率高、负载变化大、环境温度高或电源波动大等应用场合，建议电动机使用该类保护。

Insulation system

The insulation system of 1LE0001 results in high reliability, a long service life and high resistance to stress, for example, during starting or under overload conditions.

1LE0001 series motors are designed for temperature class 155 (F). At rated output with line-fed operation, the motors can be used in temperature class 130 (B).

Motor protection

Motor thermal overload protection

Motor thermal protection means to use of thermal protectors and thermal detectors incorporated into the stator windings or placed in other suitable positions in motor in order to protect them against serious damage due to thermal overloads.

The order variants for motor protection are coded with letters in the 15th position of the Motor Order No., or ordered with Option code. Some protection method about winding protection and bearing protection are shown in the following.

Winding protection

■ PTC thermistors protection

The most comprehensive protection against thermal overloading of the motor is provided by PTC thermistors (thermistor motor protection) installed in the motor winding. The temperature of the winding can be accurately monitored thanks to its low heating capacity and the excellent heat contact with the winding. When a limit temperature is reached (nominal tripping temperature), the resistance of PTC thermistors will have a step change. This is evaluated by a tripping unit and can be used to open auxiliary circuits.

The PTC thermistors themselves cannot be subjected to high currents and voltages. This would result in destruction of the semiconductor. The switching hysteresis of the PTC thermistor and tripping unit is low, which supports fast restarting of the drive. Motors with this type of protection are recommended for heavy duty starting, switching duty, extreme changes in load, high ambient temperatures or fluctuating supply systems.

PTC 曲线图
The graph of PTC

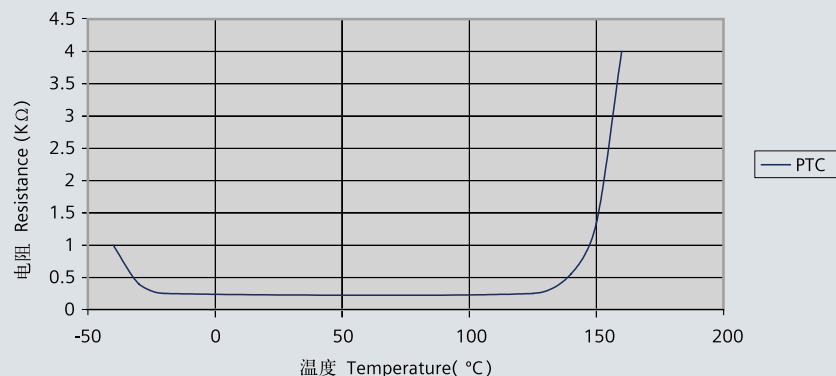

两种 PTC 热敏电阻温度保护

- 电动机绕组带一组三芯串联的 PTC 热敏电阻用于跳闸，跳闸温度为 155 °C，电动机订货号第 15 位字母为“B”，需 2 个辅助接线端子。
- 电动机绕组带两组三芯串联的 PTC 热敏电阻，其中一组用于在电动机跳闸前报警，一组用于跳闸，报警温度为 145 °C，跳闸温度为 155 °C，电动机订货号第 15 位字母为“C”，需 4 个辅助接线端子。

■ KTY84-130 温度传感器温度保护

当 1LE0001 电动机变频应用时，推荐使用 KTY84-30 温度传感器进行绕组保护。KTY84-130 温度传感器特性曲线如下所示。

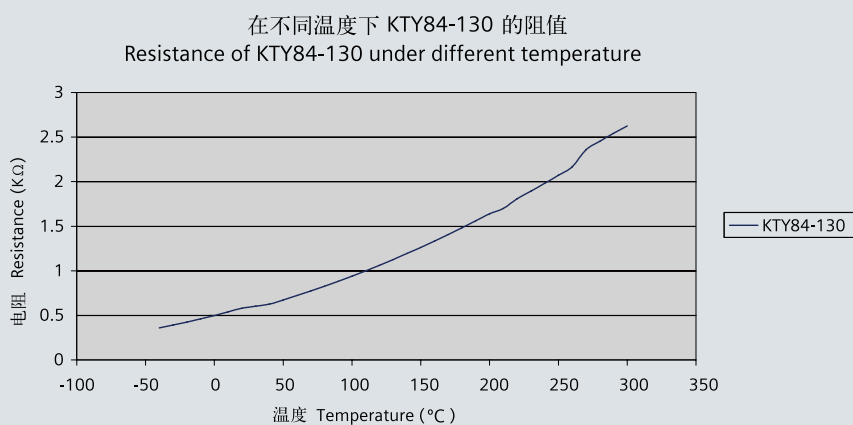

KTY 84-130 温度传感器的特性曲线 KTY84-130 sensor characteristics curve

一些西门子变频器可以通过温度传感器的电阻来确定电动机的温度，从而设定电动机报警和跳闸的温度。

1LE0001 电动机绕组带一个 KTY 84-130 温度传感器，电动机订货号第 15 位字母为“F”，需 2 个辅助接线端子。

■ PT100 热敏电阻传感器温度保护

PT100 热敏电阻是一种精确高、灵敏度高的传感器，其线性温度阻值优于其他电阻式传感器，性能稳定、可靠性高，其特性曲线如下。

两种 PT100 热敏电阻温度保护

- 电动机绕组带 3 个 2 线制 PT100 测温元件，电动机订货号第 15 位字母为“H”，需 6 个辅助接线端子。
- 电动机绕组带 6 个 2 线制 PT100 测温元件，电动机订货号第 15 位字母为“J”，需 12 个辅助接线端子。

2 alternatives of PTC protection

- Motor winding is protected with PTC thermistors with 3 embedded temperature sensors for tripping. Connection be done through 2 auxiliary terminals in the connection box. 15th position of Motor Order No. letter B.
- Motor winding is protected with two sets of three temperature sensors, one set is for warning, another set for tripping. The warning temperature is 145 °C, and tripping temperature is 155 °C. Connection be done through 4 auxiliary terminals in the connection box. 15th position of Motor Order No. letter C.

■ KTY84-130 temperature sensor protection

When 1LE0001 with converter fed operation, KTY84-30 is recommended to be configured for winding protection. The following chart show the characteristic of KTY84-30.

Some converters from Siemens determine the motor temperature using the resistance of the temperature sensor. They can be set to a required temperature for alarm and tripping.

1LE0001 Motor winding with embedded temperature detector sensor KTY 84-130. Two auxiliary terminals are provided in the connection box. 15th position of Motor Order No. letter F.

■ PT100 resistance thermometers protection

PT100 thermometers are a high precision, high sensitivity, better linear temperature resistance, more stable performance, and high reliability sensor, whose characteristics are as following.

2 alternatives of PT100

- Installation of 3 PT100 resistance thermometers. Connection be done through 6 auxiliary terminals in the connection box. 15th position of Motor Order No. letter H.
- Installation of 6 PT100 resistance thermometers. Connection be done through 12 auxiliary terminals in the connection box. 15th position of Motor Order No. letter J.

在不同温度下 PT100 的阻值
Resistance of PT100 under different temperature

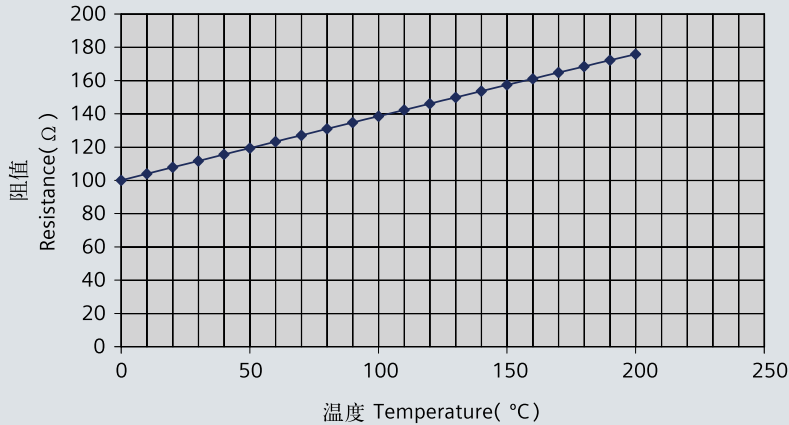

轴承保护

1LE0001 电动机轴承标配不带任何保护。对于某些苛刻的应用，推荐对轴承采取保护措施。轴承保护是通过在电动机驱动端和非驱动端的轴承端盖拧入温度传感器来进行保护。温度传感器的引线引入电动机主接线盒内。

1LE0001 电动机轴承装两个 PT100 测温元件，选件号为 Q5A，需 4 个辅助接线端子。

Bearing protection

1LE0001 motors bearing has no protection as standard. For some severe application, such as high load, high coolant temperature and etc., the bearing is recommended to be protected. The bearing is protected through thermometers screwed into the bearing plates of motor driven end (DE) and non-drive-end (NDE). The wires are routed through the main connection box.

Installation of 2 PT100 screwed-in resistance thermometers for 1LE0001 motor bearings, Option code: Q5A. Connection be done through 4 auxiliary terminals in the connection box.

防潮加热保护

当电动机处于较为恶劣的环境时，比如湿度非常大或者昼夜温差比较大，电动机的绕组很可能出现凝露的现象，这样会带来电动机烧毁的风险。对于这种情况，建议对电动机绕组配置防潮加热带（选件号：Q04）进行保护。

电动机防潮加热带必须在电动机工作过程中处于不工作状态；当电动机停机时，防潮加热带必须启动工作，为绕组加热。防潮加热带的电气参数如下表所示。

Anti-condensation heater

Motors whose windings are at risk of condensation due to the climatic conditions, e.g. inactive motors in humid atmospheres or motors that are subjected to widely fluctuating temperatures can be equipped with anti-condensation heaters (Option code: Q04).

Anti-condensation heaters must be switched off during operation. When motor shut down, the heaters must be switched on.

防潮加热带电气参数

Electrical data of Anti-condensation heater

机座号 Frame size	功率 Power (W)	电压 Voltage
80 ~ 90	20	220 V
100 ~ 112	30	220 V
132 ~ 160	40	220 V
180 ~ 200	50	220 V
225 ~ 280	60	220 V
315	80	220 V
355	100	220 V

变频应用

1LE0001 电动机适于变转速、恒转速的各种应用，如风机、泵、压缩机、纺织机械等。

当变频器驱动电动机时，电磁干扰的程度大小取决于变频器的类型（种类，IGBT 数量，干扰控制措施及制造商）、布线、距离以及应用需求。在设计 and 应用阶段必须参考变频器制造商关于电磁兼容性的安装指导。

当 1LE0001 电动机变频应用（变频器供电），且输出额定功率时，电动机的使用温度等级为 155 (F)。为了避免杂散电流对电动机轴承的损坏，推荐 FS250 ~ 355 电动机使用绝缘轴承。请向西门子咨询关于绝缘轴承的详细信息。

变频器驱动运行

1LE0001 电动机的标准绝缘系统设计要求，能够保证其在变频器供电电压不超过 460 V 时正常运行。

1LE0001 电动机带有特定的负载时能够使用变频器驱动，其特定的负载扭矩如以下图表所示：

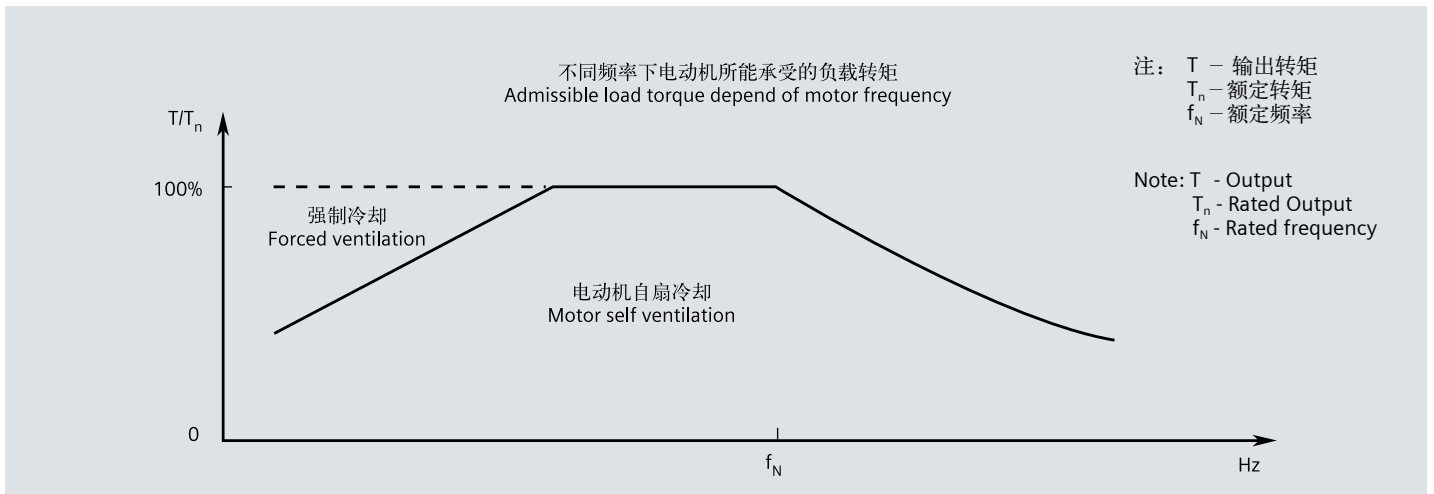

当负载扭矩在允许的扭矩范围内时，电动机能够自扇冷却；当负载扭矩超过所允许的扭矩时，电动机需要强迫冷却。

在电动机运行速度超过额定转速时，噪声和振动值将增加，并且轴承的寿命将缩短。需要注意再润滑周期和润滑脂的寿命。

变频运行时当频率超过 60 Hz 时，必需按照特定的限值进行动平衡。

Converter fed application

1LE0001 motors are suitable for pumps, fans, compressors, textile machine and mechanical machine applications where variable or constant speed is required.

In application where the motor is driven by a converter, the degree of electrical interference depends on the type of converter used (type, number of IGBTs, interference suppression measures, and manufacturer), cabling, distance and application requirements. The installation guidelines of the converter manufacturer with regards to electromagnetic compatibility must be considered at all times during the design and implementation phases.

At rated output with converter fed operation, the motors will be used in temperature class 155 (F). To prevent damage as a result of bearing currents, insulated bearings are recommended to be assembled for frame size 250 and above. Please inquire Siemens about the detailed information of insulated bearing.

Converter-fed operation

The standard insulation of the 1LE0 motors is designed such that operation is possible on the converter at mains voltage up to 460 V.

1LE0001 motors are capable for converter-fed operation with certain characteristics load, of which the load torque characteristics is referred in the following diagram:

By usage with admissible torque and below, the motor can be operated with self cooling; by usage over the admissible torque line, the motor with forced ventilation is needed.

At operating speeds above rated speed the noise and vibration levels increase and the bearing life time reduce. Attention should be paid to the re-greasing intervals and the grease service life.

For converter-fed operation with frequencies greater than 60 Hz special balancing is required for compliance with the specified limit values.

1LE0001 电动机所允许的最大安全转速如下表

The allowed maximum safe operating speed of 1LE0001 motors shows the diagram

机座号 Frame Size	2 极 2 pole		4 极 4 pole		6 极 6 pole		8 极 8 pole	
	最高转速 Max. rpm	最大频率 fmax	最高转速 Max. rpm	最大频率 fmax	最高转速 Max. rpm	最大频率 fmax	最高转速 Max. rpm	最大频率 fmax
80	5200	87	3600	120	2400	120	1800	120
90	5200	87	3600	120	2400	120	1800	120
100	5200	87	3600	120	2400	120	1800	120
112	5200	87	3600	120	2400	120	1800	120
132	4500	75	2700	90	2400	120	1800	120
160	4500	75	2700	90	2400	120	1800	120
180	4500	75	2700	90	2400	120	1800	120
200	4500	75	2300	77	1800	90	1400	93
225	3600	60	2300	77	1800	90	1400	93
250	3600	60	2300	77	1800	90	1400	93
280	3600	60	2300	77	1800	90	1400	93
315	3600	60	2300	77	1800	90	1400	93
355	3600	60	2300	77	1800	90	1400	93

电压承受值

绕组绝缘的电介质应力决定于:

- 电压峰值，上升时间以及变频器产生的脉冲频率；
- 变频器与电动机连接电缆的特性和长度；
- 绕组结构和其他系统参数，尤其是绝缘系统中不同绕组的对地电压（代表了绝缘系统的电介质应力）。

图表所示为 1LE0001 电动机标准绝缘能承受电压的峰值和上升时间：

Voltage withstand levels

The dielectric stress of the winding insulation is determined by:

- the peak voltage, rise time and frequency of the impulses produced by the converter.
- the characteristics and the length of the connection leads between the converter and motor.
- the winding construction and other system parameters, especially the voltages between the different parts of the winding and the ground represent dielectric stress at the insulation system.

The standard insulation of the 1LE0001 motors is designed to withstand voltage peak and rise time which is showed in the diagram:

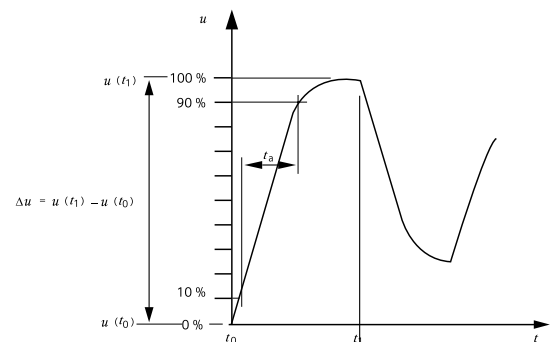
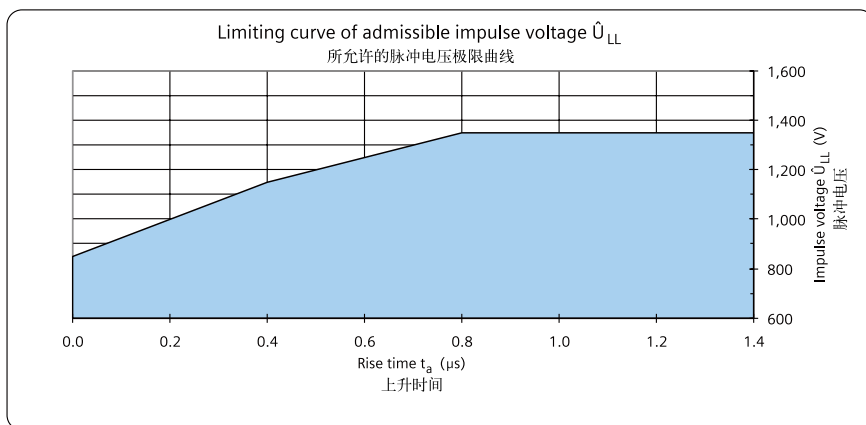

数值参照 IEC 60034-17, GB/T 20161-2008标准。

The values refer to standard IEC 60034-17 and GB/T 20161-2008.

订货号

Order No.

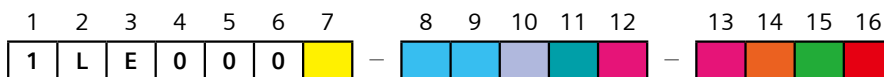

低压系列电动机 Low-voltage motor series

1 = 高效电动机, 中国能效等级 3 级
1 = High Efficiency, China Energy Efficiency Grade 3

机座号编号 Code of frame size

0D = 080; 0E = 090

1A = 100; 1B = 112; 1C = 132; 1D = 160; 1E = 180

2A = 200; 2B = 225; 2C = 250; 2D = 280

3A = 315; 3B = 355

极数编号 Code of poles

A = 2; B = 4; C = 6; D = 8

机座长度编号 Code of frame length

0 or 1 = S (短机座 short); 2 or 3 = M (中机座 medium); 4 or 5 or 6 or 7 = L (长机座 long)

电压, 连接方式和频率编号 Code of voltage, connections and frequency

04 = 400VD 50Hz

22 = 230VD/400VY 50Hz 35 = 415VD 50Hz

21 = 220VD/380VY 50Hz 23 = 240VD/415VY 50Hz 90¹⁾ = 特殊电压与频率

33 = 380VD/660VY 50Hz 34 = 400VD/690VY 50Hz special voltage & frequency

结构和安装方式编号 Code of Construction and mounting type

T³⁾ = IM B6

A^{2) 3)} = IM B3 U³⁾ = IM B7

J³⁾ IM B35 V³⁾ = IM B8

F^{3) 4) 6)} = IM B5 C^{3) 8)} = IM V5 W^{3) 8)} = IM V15 G^{3) 6) 8)} = IM V1 M^{3) 6) 7) 8)} = IM V18

K^{3) 5) 6) 7)} = IM B14 D³⁾ = IM V6 Y³⁾ = IM V35 H^{3) 6)} = IM V3 L^{3) 6) 7)} = IM V19 N^{3) 7)} = IM B34

绕组保护编号 Code of winding protection

A = 无绕组保护 without winding protection

B = 绕组带一组三芯串联的 PTC 热敏电阻用于跳闸 3 PTC thermistors for tripping

C = 绕组带两组三芯串联的 PTC 热敏电阻用于报警和跳闸 6 PTC thermistors for alarm and tripping

F = 绕组带一个 KTY 84-130 温度传感器 1 temperature sensor KTY 84-130

H = 绕组带 3 个 Pt100 测温元件 3 resistance thermometers Pt100

J = 绕组带 6 个 Pt100 测温元件 6 resistance thermometers Pt100

接线盒位置编号 (从驱动端看) Code of connection box location (view from drive end)

4 = 置顶 on top; 5⁹⁾ = 右侧 on RHS; 6⁹⁾ = 左侧 on LHS

订货号

Order No.

附注:

- 1) 用电压编号 90 及相应选件号来定制其它电压 (参见选项描述) ;
- 2) 当电动机不要求带冷凝水排放孔 (订货号: H03) 时, IM B3 安装结构型式也可适用于 IM B6/7/8、以及不带防护罩的 IM V5/6 安装结构型式的电动机 (FS80 ~ 225), 但电动机铭牌上只标示 IM B3 安装结构型式, 不标示其他安装结构型式;
- 3) 铭牌上标有结构型式。若需要冷凝水排放孔 (订货号: H03), 则必须指明电机的安装结构型式, 以便在制造过程中确定冷凝水排放孔的具体位置。
- 4) 当电动机不要求带冷凝水排放孔 (订货号: H03) 时, IM B5 安装结构型式也可适用于不带防护罩的 IM V1 和 IM V3 安装型式的电动机 (FS80 ~ 225), 但电动机铭牌上只标示 IM B5 安装结构型式, 不标示其他安装结构型式;
- 5) 当电动机不要求带冷凝水排放孔 (订货号: H03) 时, IM B14 安装结构型式也可适用于不带防护罩的 IM V18 和 IM V19 安装结构型式, 但电动机铭牌上只标示 IM B14 安装型式, 不标示其他安装结构型式;
- 6) 对于 IM B5、IM V1、IM V3、IM B14、IM V18 和 IM V19 安装结构型式电动机, 须指定电动机订货号第 16 位数字为 “4” ;
- 7) 只针对 FS80 ~ 160;
- 8) 电动机标配无防雨罩, 但如需要加带防雨罩用于防护时, 须订购选件号 H00;
- 9) FS80 ~ 132 进线孔的方向朝向非驱动端;

订货号样例:

三相低压交流电动机
4-极, 15 kW, IM B5, 380VD/660VY 50 Hz, IP55, 接线盒位置处于顶端, 进线孔右侧 (从驱动端看), 带独立驱动风扇。

电动机订货号: 1LE0001-1DB43-3FA4-Z F70

电动机订货号解释

1	L	E	0	0	0	1	-	1	D	B	4	3	-	3	F	A	4	-	Z	F	7	0
电动机 Motor																						
机座号 Frame size: 160																						
极数 Poles: 4																						
机座长度 Frame length: 长机座 (L)																						
电压, 连接方式和频率 Voltage, connection method and frequency : 380VD/660VY 50 Hz																						
结构型式 Construction : IM B5																						
绕组保护 Winding protection : 无 None																						
接线盒位置 Connection box position: 置顶 On top																						
其他技术要求 Other technical requirements : 独立驱动风扇 Separately driven fan																						

Foot note:

- 1) Order other voltages with voltage code 90 and the corresponding Option code (see under "Option") .
- 2) The types of construction IM B6/7/8, IM V6 and IM V5 without protective cover are also possible as long as no condensation drainage holes (Order code: H03) and no stamping of these types of construction on the rating plate are required. As standard, the type of construction IM B3 is then stamped on the rating plate.
- 3) The type of construction is stamped on the rating plate. When ordering with condensation drainage holes (order code H03), it is absolutely necessary to specify the type of construction for the exact position of the condensation drainage holes during manufacture.
- 4) The types of construction IM V1 and IM V3 without protective cover are also possible as long as no condensation drainage holes (Order code: H03) and no stamping of these types of construction on the rating plate are required. As standard, the type of construction IM B5 is then stamped on the rating plate.
- 5) The types of construction IM V19 and IM V18 without protective cover are also possible as long as no condensation drainage holes (Order code: H03) and no stamping of these types of construction on the rating plate are required. As standard, the type of construction IM B14 is then stamped on the rating plate.
- 6) For motor with IM B5, IM V1, IM V3, IM B14, IM V18 and IM V19 construction and mounting type, the 16th digit of motor order No. must be "4";
- 7) Only for FS80 ~ 160.
- 8) Without canopy, for protective cover with canopy needed Option code H00.
- 9) Cable entry on connection box towards the non-drive.

Order No. example:

Low voltage three phase motor
4-pole, 15 kW, IM B5, 380VD/660VY 50 Hz, IP55, connection box on top and cable entry at right side (view from DE), with separately driven fan.

Motor order code: 1LE0001-1DB43-3FA4-Z F70

Motor order code introduction

选型技术数据表 Technical data table

机座号 Frame Size	额定功率 (50Hz) Rated Output (50Hz)	额定功率 (60Hz) Rated Output (60Hz)	型号 Order No.	额定 转速 Rated Speed	效率 (50Hz) Effeciency at (50 HZ) 4/4 load	效率 (50Hz) Effeciency at (50 HZ) 3/4 load	功率因数 (50Hz) Power factor (50Hz)	额定电流 (50Hz) Rated current (50Hz)
	kW	kW		rpm	%	%		A
3000rpm 2-pole								
220VD/380VY 50 HZ								
80M	0.75	0.86	1LE0001-0DA22-1□□□□	2795	77.4	78.5	0.84	1.75
80M	1.1	1.3	1LE0001-0DA32-1□□□□	2835	79.6	80.6	0.84	2.50
90S	1.5	1.75	1LE0001-0EA02-1□□□□	2890	81.3	81.7	0.84	3.35
90L	2.2	2.55	1LE0001-0EA42-1□□□□	2890	83.2	83.7	0.85	4.75
100L	3	3.45	1LE0001-1AA42-1□□□□	2885	84.6	85.1	0.84	6.4
3000rpm 2-pole								
380VD/660VY 50 HZ								
112M	4	4.6	1LE0001-1BA23-3□□□□	2930	85.8	86.6	0.86	8.2
132S	5.5	6.3	1LE0001-1CA03-3□□□□	2930	87	87.6	0.87	11.0
132S	7.5	8.6	1LE0001-1CA13-3□□□□	2930	88.1	88.8	0.89	14.5
160M	11	12.6	1LE0001-1DA23-3□□□□	2935	89.4	90.1	0.86	21.5
160M	15	17.3	1LE0001-1DA33-3□□□□	2935	90.3	91	0.86	29.5
160L	18.5	21.3	1LE0001-1DA43-3□□□□	2935	90.9	91.7	0.89	34.5
180M	22	24.5	1LE0001-1EA23-3□□□□	2935	91.3	91.8	0.87	42.0
200L	30	33.5	1LE0001-2AA43-3□□□□	2955	92	92.3	0.86	58
200L	37	41.5	1LE0001-2AA53-3□□□□	2955	92.5	92.8	0.88	69
225M	45	51	1LE0001-2BA23-3□□□□	2965	92.9	93.1	0.88	84
250M	55	62	1LE0001-2CA23-3□□□□	2970	93.2	93.2	0.88	102
280S	75	84	1LE0001-2DA03-3□□□□	2975	93.8	93.8	0.87	140
280M	90	101	1LE0001-2DA23-3□□□□	2978	94.1	94.1	0.87	167
315S	110	123	1LE0001-3AA03-3□□□□	2982	94.3	94.3	0.90	197
315M	132	148	1LE0001-3AA23-3□□□□	2982	94.6	94.6	0.91	235
315L	160	180	1LE0001-3AA53-3□□□□	2982	94.8	95.1	0.92	280
315L	185	207	1LE0001-3AA63-3□□□□	2982	95	95.3	0.92	320
315L	200	224	1LE0001-3AA73-3□□□□	2982	95	95.3	0.92	350
355M	220	246	1LE0001-3BA23-3□□□□	2980	95	95	0.90	390
355M	250	280	1LE0001-3BA33-3□□□□	2980	95	95	0.90	445
355L	280	314	1LE0001-3BA53-3□□□□	2980	95	95.1	0.90	500
355L	315	353	1LE0001-3BA63-3□□□□	2980	95	95.1	0.90	560

注：关于其他电压与频率、绕组保护以及接线盒位置的编码，请见第 20 页订货号。

Note: About the code of other voltage and frequency, winding protection and connection box position, please refer to Orde No. in page 20.

型号 Order No.	额定转矩 Rated torque	起动电流/ 额定电流 Starting current / Rated current	起动转矩/ 额定转矩 Starting torque / Rated torque	最大转矩 / 额定转矩 Max torque / Rated torque	转动惯量 Moment of inertia (J)	重量 Weight IMB3
	Nm	I_{LR} / I_{rated}	T_{LR} / T_{rated}	T_{max} / T_{rated}	kgm ²	kg
3000rpm 2-pole						
220VD/380VY 50 HZ						
1LE0001-0DA22-1□□□	2.6	5.6	2.4	2.4	0.00080	15.5
1LE0001-0DA32-1□□□	3.7	6	2.8	3.2	0.0012	16.5
1LE0001-0EA02-1□□□	5.0	6.5	2.4	3.1	0.0021	20
1LE0001-0EA42-1□□□	7.3	7.2	2.6	3.5	0.0026	23
1LE0001-1AA42-1□□□	9.9	7.5	4	4.5	0.0036	34
3000rpm 2-pole						
380VD/660VY 50 HZ						
1LE0001-1BA23-3□□□	13.0	7.5	2.2	2.9	0.0064	40
1LE0001-1CA03-3□□□	17.9	7.5	2.2	2.9	0.014	56
1LE0001-1CA13-3□□□	24.4	7.5	2.3	2.9	0.017	62
1LE0001-1DA23-3□□□	35.8	7.5	2.2	2.9	0.031	96
1LE0001-1DA33-3□□□	48.8	7.5	2.4	3.2	0.038	106
1LE0001-1DA43-3□□□	60.2	7.5	2.4	3.2	0.046	125
1LE0001-1EA23-3□□□	71.6	7.6	2.5	3.2	0.072	152
1LE0001-2AA43-3□□□	97.0	7.5	2.5	3.2	0.13	229
1LE0001-2AA53-3□□□	119.6	7.5	2.5	3.2	0.15	245
1LE0001-2BA23-3□□□	144.9	7.9	2.5	3.1	0.24	307
1LE0001-2CA23-3□□□	176.9	7.5	2.5	3	0.42	378
1LE0001-2DA03-3□□□	240.8	7.5	2.8	3	0.75	550
1LE0001-2DA23-3□□□	288.6	7.5	3	3.1	0.88	570
1LE0001-3AA03-3□□□	352.3	7.5	2.2	2.6	1.4	740
1LE0001-3AA23-3□□□	422.7	7.5	2.3	2.9	1.7	855
1LE0001-3AA53-3□□□	512.4	7.5	2.5	2.8	1.9	970
1LE0001-3AA63-3□□□	592.5	7.5	2.5	2.8	2.3	1080
1LE0001-3AA73-3□□□	640.5	7.5	2.5	2.8	2.3	1090
1LE0001-3BA23-3□□□	705.0	7.1	2	2.2	2.9	1600
1LE0001-3BA33-3□□□	801.2	7.1	2	2.2	3.0	1650
1LE0001-3BA53-3□□□	897.3	7.1	2	2.2	3.5	1830
1LE0001-3BA63-3□□□	1009.5	7.1	2	2.3	3.5	1840

选型技术数据表 Technical data table

机座号 Frame Size	额定功率 (50Hz) Rated Output (50Hz)	额定功率 (60Hz) Rated Output (60Hz)	型号 Order No.	额定 转速 Rated Speed	效率 (50Hz) Effeciency at (50 HZ) 4/4 load	效率 (50Hz) Effeciency at (50 HZ) 3/4 load	功率因数 (50Hz) Power factor (50Hz)	额定电流 (50Hz) Rated current (50Hz)
	kW	kW		rpm	%	%		A
1500rpm 4-pole								
220VD/380VY 50 HZ								
80M	0.55	0.63	1LE0001-0DB22-1□□□□	1425	74.0	74.7	0.8	1.40
80M	0.75	0.86	1LE0001-0DB32-1□□□□	1440	79.6	79.6	0.75	1.90
90S	1.1	1.3	1LE0001-0EB02-1□□□□	1440	81.4	81.4	0.75	2.75
90L	1.5	1.75	1LE0001-0EB42-1□□□□	1440	82.8	82.8	0.76	3.60
100L	2.2	2.55	1LE0001-1AB42-1□□□□	1435	84.3	85	0.79	5.0
100L	3	3.45	1LE0001-1AB52-1□□□□	1435	85.5	86.3	0.79	6.7
1500rpm 4-pole								
380VD/660VY 50 HZ								
112M	4	4.6	1LE0001-1BB23-3□□□□	1445	86.6	87.1	0.79	8.9
132S	5.5	6.3	1LE0001-1CB03-3□□□□	1460	87.7	88.2	0.79	12.1
132M	7.5	8.6	1LE0001-1CB23-3□□□□	1460	88.7	89.4	0.82	15.7
160M	11	12.6	1LE0001-1DB23-3□□□□	1465	89.8	90.4	0.84	22.0
160L	15	17.3	1LE0001-1DB43-3□□□□	1465	90.6	91.3	0.85	29.5
180M	18.5	21.3	1LE0001-1EB23-3□□□□	1465	91.2	91.8	0.85	36.5
180L	22	24.5	1LE0001-1EB43-3□□□□	1465	91.6	92.3	0.85	43.0
200L	30	33.5	1LE0001-2AB43-3□□□□	1470	92.3	92.9	0.85	58
225S	37	41.5	1LE0001-2BB03-3□□□□	1475	92.7	93.2	0.86	71
225M	45	51	1LE0001-2BB23-3□□□□	1475	93.1	93.5	0.87	84
250M	55	62	1LE0001-2CB23-3□□□□	1480	93.5	93.9	0.86	104
280S	75	84	1LE0001-2DB03-3□□□□	1485	94	94.3	0.87	139
280M	90	101	1LE0001-2DB23-3□□□□	1485	94.2	94.3	0.87	167
315S	110	123	1LE0001-3AB03-3□□□□	1488	94.5	94.5	0.86	205
315M	132	148	1LE0001-3AB23-3□□□□	1486	94.7	94.7	0.88	240
315L	160	180	1LE0001-3AB53-3□□□□	1488	94.9	94.9	0.88	290
315L	185	207	1LE0001-3AB63-3□□□□	1488	95.1	95.1	0.88	335
315L	200	224	1LE0001-3AB73-3□□□□	1488	95.1	95.1	0.88	365
355M	220	246	1LE0001-3BB23-3□□□□	1490	95.1	95.2	0.90	390
355M	250	280	1LE0001-3BB33-3□□□□	1490	95.1	95.2	0.90	445
355L	280	314	1LE0001-3BB53-3□□□□	1490	95.1	95.2	0.90	495
355L	315	353	1LE0001-3BB63-3□□□□	1490	95.1	95.2	0.90	560

注：关于其他电压与频率、绕组保护以及接线盒位置的编码，请见第 20 页订货号。

Note: About the code of other voltage and frequency, winding protection and connection box position, please refer to Orde No. in page 20.

型号 Order No.	额定转矩 (50 HZ) Rated torque (50 HZ)	起动电流/ 额定电流 Starting current / Rated current	起动转矩/ 额定转矩 Starting torque / Rated torque	最大转矩 / 额定转矩 Max torque / Rated torque	转动惯量 Moment of inertia (J)	重量 Weight IMB3
	Nm	I_{LR} / I_{rated}	T_{LR} / T_{rated}	T_{max} / T_{rated}	kgm ²	kg
1500rpm 4-pole						
220VD/380VY 50 HZ						
1LE0001-0DB22-1□□□	3.7	6	2	2.7	0.0021	17.5
1LE0001-0DB32-1□□□	5.0	6.5	2.8	3.5	0.0027	17
1LE0001-0EB02-1□□□	7.3	7	2.8	3.5	0.0041	20
1LE0001-0EB42-1□□□	9.9	7	3	3.8	0.0047	24
1LE0001-1AB42-1□□□	14.6	7	3	3.2	0.0081	32
1LE0001-1AB52-1□□□	20.0	7	3	3.2	0.010	34
1500rpm 4-pole						
380VD/660VY 50 HZ						
1LE0001-1BB23-3□□□	26.4	7.1	2.7	3.1	0.011	45
1LE0001-1CB03-3□□□	36.0	7.5	2.5	3.1	0.021	61
1LE0001-1CB23-3□□□	49.1	7.7	2.7	3.2	0.029	73
1LE0001-1DB23-3□□□	71.7	7.5	2.5	3.1	0.051	103
1LE0001-1DB43-3□□□	97.8	7.8	2.7	3.2	0.066	130
1LE0001-1EB23-3□□□	120.6	7.3	2.5	3.2	0.13	165
1LE0001-1EB43-3□□□	143.4	7.3	2.4	3.2	0.14	180
1LE0001-2AB43-3□□□	194.9	7.3	2.7	3.2	0.22	238
1LE0001-2BB03-3□□□	239.6	7.3	2.7	3.2	0.45	298
1LE0001-2BB23-3□□□	291.4	7.3	2.7	3.2	0.51	322
1LE0001-2CB23-3□□□	354.9	7.5	3.1	3.5	0.80	410
1LE0001-2DB03-3□□□	482.3	7.5	2.7	3.1	1.4	555
1LE0001-2DB23-3□□□	578.8	7.5	2.7	3.1	1.5	610
1LE0001-3AB03-3□□□	706.0	7.3	2.8	2.9	2.2	750
1LE0001-3AB23-3□□□	848.3	7.3	2.5	2.7	2.5	875
1LE0001-3AB53-3□□□	1026.9	7.4	3	2.9	3.0	960
1LE0001-3AB63-3□□□	1187.3	7.4	3	3	3.6	1070
1LE0001-3AB73-3□□□	1283.6	7.4	3	3	3.7	1080
1LE0001-3BB23-3□□□	1410.1	6.9	2	2.2	6.6	1640
1LE0001-3BB33-3□□□	1602.3	6.9	2	2.2	6.9	1680
1LE0001-3BB53-3□□□	1794.6	6.9	2	2.2	7.7	1830
1LE0001-3BB63-3□□□	2019.0	6.9	2	2.2	8.5	1900

选型技术数据表 Technical data table

机座号 Frame Size	额定功率 (50Hz) Rated Output (50Hz)	额定功率 (60Hz) Rated Output (60Hz)	型号 Order No.	额定 转速 Rated Speed	效率 (50Hz) Effeciency at (50 HZ) 4/4 load	效率 (50Hz) Effeciency at (50 HZ) 3/4 load	功率因数 (50Hz) Power factor (50Hz)	额定电流 (50Hz) Rated current (50Hz)
	kW	kW		rpm	%	%		A
1000rpm 6-pole								
220VD/380VY 50 HZ								
80M	0.55	0.63	1LE0001-0DC32-1□□□□	895	71	72	0.76	1.55
90S	0.75	0.86	1LE0001-0EC02-1□□□□	935	75.9	76.5	0.71	2.10
90L	1.1	1.3	1LE0001-0EC42-1□□□□	945	78.1	78.1	0.71	3.00
100L	1.5	1.75	1LE0001-1AC42-1□□□□	945	79.8	80.1	0.74	3.85
112M	2.2	2.55	1LE0001-1BC22-1□□□□	950	81.8	82.5	0.73	5.6
132S	3	3.45	1LE0001-1CC02-1□□□□	960	83.3	84.3	0.73	7.5
1000rpm 6-pole								
380VD/660VY 50 HZ								
132M	4	4.6	1LE0001-1CC23-3□□□□	960	84.6	85.4	0.73	9.8
132M	5.5	6.3	1LE0001-1CC33-3□□□□	960	86	86.6	0.75	13.0
160M	7.5	8.6	1LE0001-1DC23-3□□□□	965	87.2	87.9	0.77	17.0
160L	11	12.6	1LE0001-1DC43-3□□□□	965	88.7	89.4	0.78	24.0
180L	15	17.3	1LE0001-1EC43-3□□□□	975	89.7	90.4	0.78	32.5
200L	18.5	21.3	1LE0001-2AC43-3□□□□	975	90.4	91	0.81	38.5
200L	22	24.5	1LE0001-2AC53-3□□□□	975	90.9	91.4	0.82	45.0
225M	30	33.5	1LE0001-2BC23-3□□□□	980	91.7	92.3	0.83	60
250M	37	41.5	1LE0001-2CC23-3□□□□	982	92.2	92.8	0.83	73
280S	45	51	1LE0001-2DC03-3□□□□	985	92.7	93.3	0.85	87
280M	55	62	1LE0001-2DC23-3□□□□	986	93.1	93.7	0.85	106
315S	75	84	1LE0001-3AC03-3□□□□	986	93.7	94.3	0.85	143
315M	90	101	1LE0001-3AC23-3□□□□	986	94	94.5	0.85	171
315L	110	123	1LE0001-3AC53-3□□□□	988	94.3	94.7	0.86	205
315L	132	148	1LE0001-3AC63-3□□□□	988	94.6	95	0.86	245
355M	160	180	1LE0001-3BC23-3□□□□	990	94.8	95.1	0.87	295
355M	185	207	1LE0001-3BC33-3□□□□	990	95	95.3	0.87	340
355M	200	224	1LE0001-3BC43-3□□□□	990	95	95.3	0.87	370
355L	220	246	1LE0001-3BC53-3□□□□	990	95	95.3	0.87	405
355L	250	280	1LE0001-3BC63-3□□□□	990	95	95.3	0.87	460

注：关于其他电压与频率、绕组保护以及接线盒位置的编码，请见第 20 页订货号。

Note: About the code of other voltage and frequency, winding protection and connection box position, please refer to Orde No. in page 20.

型号 Order No.	额定转矩 Rated torque	起动电流/ 额定电流 Starting current / Rated current	起动转矩/ 额定转矩 Starting torque / Rated torque	最大转矩 / 额定转矩 Max torque / Rated torque	转动惯量 Moment of inertia (J)	重量 Weight IMB3
	Nm	I_{LR} / I_{rated}	T_{LR} / T_{rated}	T_{max} / T_{rated}	kgm ²	kg
1000rpm 6-pole						
220VD/380VY 50 HZ						
1LE0001-ODC32-1□□□	5.9	4.5	2.3	2.3	0.0028	17.5
1LE0001-OEC02-1□□□	7.7	5	2.1	2.6	0.0038	20
1LE0001-OEC42-1□□□	11.1	5.5	2.4	2.8	0.0046	25
1LE0001-1AC42-1□□□	15.2	5.5	2.4	2.9	0.0086	33
1LE0001-1BC22-1□□□	22.1	5.5	2.6	3.3	0.012	44
1LE0001-1CC02-1□□□	29.8	6	2	2.2	0.019	56
1000rpm 6-pole						
380VD/660VY 50 HZ						
1LE0001-1CC23-3□□□	39.8	6.2	2.2	2.5	0.024	66
1LE0001-1CC33-3□□□	54.7	6.4	2.4	2.6	0.031	75
1LE0001-1DC23-3□□□	74.2	6.4	2.1	2.6	0.056	104
1LE0001-1DC43-3□□□	108.9	6.4	2.1	2.6	0.077	132
1LE0001-1EC43-3□□□	146.9	6.5	2.3	3	0.18	170
1LE0001-2AC43-3□□□	181.2	6.5	2.3	2.8	0.27	220
1LE0001-2AC53-3□□□	215.5	6.5	2.3	2.8	0.32	240
1LE0001-2BC23-3□□□	292.3	6.5	2.2	2.8	0.62	294
1LE0001-2CC23-3□□□	359.8	7	2.5	2.8	0.91	394
1LE0001-2DC03-3□□□	436.3	7.5	2.5	2.8	1.2	510
1LE0001-2DC23-3□□□	532.7	7.5	2.5	2.8	1.5	535
1LE0001-3AC03-3□□□	726.4	7.3	2.3	2.8	2.3	680
1LE0001-3AC23-3□□□	871.7	7.3	2.3	2.8	2.8	835
1LE0001-3AC53-3□□□	1063.3	7.5	2.4	2.8	3.9	975
1LE0001-3AC63-3□□□	1275.9	7.5	2.5	3	4.3	1030
1LE0001-3BC23-3□□□	1543.4	6.7	1.9	2	7.7	1650
1LE0001-3BC33-3□□□	1784.6	6.7	1.9	2	8.4	1690
1LE0001-3BC43-3□□□	1929.3	6.7	1.9	2	9.1	1730
1LE0001-3BC53-3□□□	2122.2	6.7	1.9	2	10.1	1850
1LE0001-3BC63-3□□□	2411.6	6.7	1.9	2	11.4	1930

选型技术数据表 Technical data table

机座号 Frame Size	额定功率 (50Hz) Rated Output (50Hz)	额定功率 (60Hz) Rated Output (60Hz)	型号 Order No.	额定 转速 Rated Speed	效率 (50Hz) Effeciency at (50 HZ) 4/4 load	效率 (50Hz) Effeciency at (50 HZ) 3/4 load	功率因数 (50Hz) Power factor (50Hz)	额定电流 (50Hz) Rated current (50Hz)
	kW	kW		rpm	%	%		A
750rpm 8-pole								
220VD/380VY 50Hz								
132S	2.2	2.55	1LE0001-1CD02-1□□□□	720	79.3	80	0.6	12.1
132M	3	3.45	1LE0001-1CD22-1□□□□	720	81.2	81.5	0.6	16.2
750rpm 8-pole								
380VD/660VY 50Hz								
160M	4	4.6	1LE0001-1DD23-3□□□□	730	82.8	83	0.66	11.1
160M	5.5	6.3	1LE0001-1DD33-3□□□□	720	84.5	84.8	0.68	14.5
160L	7.5	8.6	1LE0001-1DD43-3□□□□	725	86	86.2	0.67	19.8
180L	11	12.6	1LE0001-1ED43-3□□□□	715	87.7	88	0.75	25.5
200L	15	17.3	1LE0001-2AD53-3□□□□	715	88.9	89	0.78	33
225S	18.5	21.3	1LE0001-2BD03-3□□□□	729	89.7	90	0.77	42
225M	22	24.5	1LE0001-2BD23-3□□□□	728	90.3	90.6	0.79	48
250M	30	33.5	1LE0001-2CD23-3□□□□	732	91.3	91.5	0.81	64
280S	37	41.5	1LE0001-2DD03-3□□□□	736	91.9	92	0.78	79
280M	45	51	1LE0001-2DD23-3□□□□	738	92.4	92.5	0.79	94
315S	55	62	1LE0001-3AD03-3□□□□	740	92.9	93	0.81	112
315M	75	84	1LE0001-3AD23-3□□□□	738	93.5	94	0.81	151
315L	90	101	1LE0001-3AD53-3□□□□	738	93.9	94.5	0.83	175
315L	110	123	1LE0001-3AD63-3□□□□	741	94.2	94.5	0.83	220
355M	132	148	1LE0001-3BD23-3□□□□	742	94.4	94.6	0.82	255
355M	160	180	1LE0001-3BD33-3□□□□	742	94.6	94.7	0.82	310
355L	185	207	1LE0001-3BD53-3□□□□	742	94.8	94.8	0.82	350
355L	200	224	1LE0001-3BD63-3□□□□	742	94.8	94.9	0.82	380

注：关于其他电压与频率、绕组保护以及接线盒位置的编码，请见第 20 页订货号。

Note: About the code of other voltage and frequency, winding protection and connection box position, please refer to Orde No. in page 20.

型号 Order No.	额定转矩 Rated torque	起动电流/ 额定电流 Starting current / Rated current	起动转矩/ 额定转矩 Starting torque / Rated torque	最大转矩 / 额定转矩 Max torque / Rated torque	转动惯量 Moment of inertia (J)	重量 Weight IMB3
	Nm	I_{LR} / I_{rated}	T_{LR} / T_{rated}	T_{max} / T_{rated}	kgm ²	kg
750rpm 8-pole						
220VD/380VY 50Hz						
1LE0001-1CD02-1□□□□	29.2	4.6	1.9	3	0.022	65
1LE0001-1CD22-1□□□□	40	4.8	2	3	0.037	74
750rpm 8-pole						
380VD/660VY 50Hz						
1LE0001-1DD23-3□□□□	52	4.9	1.8	2.8	0.051	100
1LE0001-1DD33-3□□□□	73	4.6	1.5	2.0	0.051	101
1LE0001-1DD43-3□□□□	99	5	1.7	2.3	0.067	128
1LE0001-1ED43-3□□□□	147	5	2.1	2.6	0.2	170
1LE0001-2AD53-3□□□□	200	6	2.3	2.9	0.35	240
1LE0001-2BD03-3□□□□	240	6.6	2.4	3	0.48	297
1LE0001-2BD23-3□□□□	290	7	2.7	2.8	0.56	307
1LE0001-2CD23-3□□□□	390	6.3	2.2	2.7	0.94	394
1LE0001-2DD03-3□□□□	480	6.5	2.5	2.7	1.2	510
1LE0001-2DD23-3□□□□	582	6.3	2.2	2.7	1.5	535
1LE0001-3AD03-3□□□□	710	6.2	2	2.9	2.1	670
1LE0001-3AD23-3□□□□	970	6.7	2.2	2.5	2.6	835
1LE0001-3AD53-3□□□□	1165	5.9	1.8	2.3	3.3	880
1LE0001-3AD63-3□□□□	1418	7.1	2.3	3	4.2	1030
1LE0001-3BD23-3□□□□	1699	6.4	1.7	2.4	7.5	1600
1LE0001-3BD33-3□□□□	2059	6.7	1.9	2.4	8.3	1640
1LE0001-3BD53-3□□□□	2381	6.3	1.7	2.3	1.3	1800
1LE0001-3BD63-3□□□□	2574	6.4	1.8	2.3	11.5	1870

选件 Options

电动机订货号 Motor order code	选件号 Option Code ¹⁾	描述 Description	应用范围 Application Scope
电压与频率 Voltages and frequency			
1LE0001-□□□□2-1□□□□	—	220VD / 380VY 50 Hz (0.55 kW ~ 3 kW ²⁾)	FS80 ~ 355
1LE0001-□□□□3-3□□□□	—	380VD / 660VY 50 Hz (4 kW ~ 315 kW ²⁾)	FS80 ~ 355
1LE0001-□□□□2-2□□□□	—	230VD / 400VY 50 Hz	FS80 ~ 355
1LE0001-□□□□3-4□□□□	—	400VD / 690VY 50 Hz	FS80 ~ 355
1LE0001-□□□□2-3□□□□	—	240VD / 415VY 50 Hz	FS80 ~ 355
1LE0001-□□□□0-4□□□□	—	400VD 50 Hz	FS80 ~ 355
1LE0001-□□□□3-5□□□□	—	415VD 50 Hz	FS80 ~ 355
1LE0001-□□□□9-0□□□□-Z	M1A	220VD / 380VY 60 Hz (60 Hz output) 60 Hz 输出	FS80 ~ 355
1LE0001-□□□□9-0□□□□-Z	M1B	380VD / 660VY 60 Hz (60 Hz output) 60 Hz 输出	FS80 ~ 355
1LE0001-□□□□9-0□□□□-Z	M1C	440VY 60Hz (60Hz output) 60Hz 输出	FS80 ~ 355
1LE0001-□□□□9-0□□□□-Z	M1D	440VD 60Hz (60Hz output) 60Hz 输出	FS80 ~ 355
1LE0001-□□□□9-0□□□□-Z	M1E	460VY 60 Hz (60 Hz output) 60 Hz 输出	FS80 ~ 355
1LE0001-□□□□9-0□□□□-Z	M1F	460VD 60 Hz (60 Hz output) 60 Hz 输出	FS80 ~ 355
1LE0001-□□□□9-0□□□□-Z	M2A	220VD/380VY 60Hz (50Hz output, 50Hz 功率输出)	FS80 ~ 355
1LE0001-□□□□9-0□□□□-Z	M2B	380VD/660VY 60Hz (50Hz output, 50Hz 功率输出)	FS80 ~ 355
1LE0001-□□□□9-0□□□□-Z	M2C	440VY 60Hz (50Hz output, 50Hz 功率输出)	FS80 ~ 355
1LE0001-□□□□9-0□□□□-Z	M2D	440VD 60Hz (50Hz output, 50Hz 功率输出)	FS80 ~ 355
1LE0001-□□□□9-0□□□□-Z	M2E	460VY 60Hz (50Hz output, 50Hz 功率输出)	FS80 ~ 355
1LE0001-□□□□9-0□□□□-Z	M2F	460VD 60Hz (50Hz output, 50Hz 功率输出)	FS80 ~ 355
1LE0001-□□□□9-0□□□□-Z	X04	480VY 60Hz (60Hz output) 60Hz 输出	FS80 ~ 355
1LE0001-□□□□9-0□□□□-Z	X20	480VD 60Hz (60Hz output) 60Hz 输出	FS80 ~ 355
绕组保护 Motor protection			
1LE0001-□□□□□-□□A□ ²⁾	—	无绕组保护 Without motor protection	FS80 ~ 355
1LE0001-□□□□□-□□B□	—	绕组带一组三芯串联的 PTC 热敏电阻用于跳闸 Motor protection with PTC thermistors with three embedded temperature sensors for tripping	FS80 ~ 355

电动机订货号 Motor order code	选件号 Option Code ¹⁾	描述 Description	应用范围 Application Scope
绕组保护 Motor protection			
1LE0001-□□□□□□-□□C□	—	绕组带两组三芯串联的 PTC 热敏电阻用于报警和跳闸 Motor protection with PTC thermistors with six embedded temperature sensors for alarm & tripping	FS80 ~ 355
1LE0001-□□□□□□-□□F□	—	绕组带一个 KTY 84-130 温度传感器 Motor temperature detection with embedded temperature sensor KTY84-130	FS100 ~ 355
1LE0001-□□□□□□-□□H□	—	绕组带 3 个 Pt100 测温元件 Installation of three PT100 resistance thermometers	FS80 ~ 355
1LE0001-□□□□□□-□□J□	—	绕组带 6 个 Pt100 测温元件 Installation of six PT100 resistance thermometers	FS80 ~ 355
线圈和绝缘 Windings and insulation			
—	N01	温度等级 155 (F) , 使用 155 (F) , 带有服务系数 (SF1.15) Temperature class 155 (F), used according to 155 (F), with service factor (SF1.15)	FS80 ~ 355
—	N10	180 (H) 度温度等级绝缘 Temperature class 180 (H)	FS80 ~ 355
—	Q04	绕组带 220 V 防潮加热带 Anti-condensation heater for 220 VAC (spaces heater)	FS80 ~ 355
电动机接线盒 Motor connection box			
1LE0001-□□□□□□-□□□4 ²⁾	—	接线盒在顶端 Connection box on top 进线孔在右侧 (从驱动端看) (标准电动机) cable entry on right (view from DE) (Standard version)	FS80 ~ 355
1LE0001-□□□□□□-□□□5	—	接线盒在右边 (从驱动端看) Connection box on RHS (view from DE)	FS80 ~ 355
1LE0001-□□□□□□-□□□6	—	接线盒在左边 (从驱动端看) Connection box on LHS (view from DE)	FS80 ~ 355
—	R10 ³⁾	接线盒直接旋转 90°, 进线口朝向驱动端 Rotation of the connection box through 90°, entry from DE	FS80 ~ 355
—	R11	接线盒直接旋转 90°, 进线口朝向非驱动端 Rotation of the connection box through 90°, entry from NDE	FS80 ~ 355
—	R12	接线盒直接旋转 180° Rotation of the connection box through 180°	FS80 ~ 355
—	H08 ⁴⁾	接线盒在非驱动端 Connection box on NDE	FS80 ~ 355
—	L97	辅助接线盒 Additional connection box	FS200 ~ 355

选件 Options

电动机订货号 Motor order code	选件号 Option Code ¹⁾	描述 Description	应用范围 Application Scope
轴承 Bearings			
—	L80	SKF 轴承 SKF Bearing	FS80 ~ 355
—	L22 ⁵⁾	增强悬臂力轴承设计 Bearing design for increased cantilever forces	FS100 ~ 355
—	L20	驱动端轴承固定 Located bearing at DE	FS80 ~ 160
—	L23 ⁶⁾	再润滑装置 Regreasing device	FS100 ~ 250
—	Q5A	轴承带两个 PT100 测温元件 Installation of 2PT100 screw-in resistance thermometers for bearing	FS180 ~ 355
—	L27 ⁷⁾	绝缘轴承 Insulated bearing	FS250 ~ 355
—	Q01	驱动端预留 SPM 测量接头 Measuring nipple for SPM shock pulse at DE measurement for bearing inspection	FS100 ~ 355
平衡 Balance and vibration quantity			
—	L00	B 级振动等级 Vibration quantity level B	FS80 ~ 355
机械设计和防护等级 Mechanical design and degrees of protection			
—	L05 ^{8) 9)}	第二标准轴伸 Second standard shaft extension	FS80 ~ 355
—	H00 ¹⁰⁾	电动机带防护罩 Motor with protective cover	FS80 ~ 355
—	H03 ¹¹⁾	冷凝水排放孔 Condensation drainage holes	FS80 ~ 355
—	H04	外部接地 External earthing	FS80 ~ 280
—	H22	IP56 防护等级 (非高海况) IP56 degree of protection (non-heavy-sea)	FS80 ~ 355
模块化技术 Modular technology			
—	F70 ¹²⁾	IC 416 冷却方式 (非自冷), 电动机带独立驱动风扇 Mounting of separately driven fan	FS80 ~ 355
—	F90 ¹³⁾	风机电机 (无风扇和风扇罩, 非驱动端全封闭) Fan motor (Without fan and fan cover, NDE closed)	FS80 ~ 355
—	F76	金属风扇 Metal fan	FS80 ~ 355
—	X05	预留安装 LL861900220 编码器位置 Prepared for of LL861900220 encoder	FS112 ~ 355
—	G04	安装编码器 LL861900200 Mounting of LL861900220 rotary pulse encoder	FS112 ~ 355
—	X50 ¹⁴⁾	安装欧姆龙编码器 (E6B2-CWZ6C) 和独立驱动风扇 Mounting of Omron rotary pulse encoder (E6B2-C) and separately driven fan	FS80 ~ 355
—	W74 ¹⁵⁾	安装欧姆龙编码器 (E6B2-CWZ1X) 和独立驱动风扇 Mounting of Omron encoder (E6B2-CWZ1X) and separated driven fan	FS80 ~ 355
铭牌和测试证书 Rating plate and test certificates			
—	B02	出厂检验报告 Acceptance test certificate 3.1 in accordance with EN 10204	FS80 ~ 355

电动机订货号 Motor order code	选件号 Option Code ¹⁾	描述 Description	应用范围 Application Scope
喷漆 Paint finish			
—	S01	不喷漆，只带底漆 Unpainted, only primed	FS80 ~ 355
—	S80	标准喷漆，颜色为 RAL 7032 Standard finish in RAL 7032	FS80 ~ 355
—	S81	标准喷漆，颜色为 RAL 9006 Standard finish in RAL 9006	FS80 ~ 355
—	W88 ¹⁶⁾	适用 TH, W, F1, WF1 以及海洋性气候环境用电机 Design for TH, W, F1, WF1 and Sea air resistant	FS80 ~ 355
环境温度 Coolant temperature			
—	D03	用于环境温度 -40 °C ~ +40 °C 下使用的电机 Coolant temperature -40 °C to + 40 °C	FS80 ~ 355

- ¹⁾ 订货时，电动机订货号需带“-Z”，另外附带上选件号；
- ²⁾ 无需附加费用；
- ³⁾ 对于 FS80 ~ 112 电动机只有接线盒在非驱动端（选件号：H08）时，才可以选此选件；
- ⁴⁾ 进线孔方向朝向驱动端；
- ⁵⁾ 对于立式安装的FS250~FS355电动机，需要特殊咨询西门子。
- ⁶⁾ 对于 FS280, FS315 和 FS355，加排油装置是标配；
- ⁷⁾ 对于水平安装的电机，绝缘轴承放置非驱动端。对于立式安装的电机，当后端是角接触轴承时，绝缘轴承放置在驱动端；
- ⁸⁾ 带防雨罩或独立驱动风扇的电动机不能选此选件；
- ⁹⁾ 非驱动端上的第二轴尺寸与驱动端轴伸不一致；
- ¹⁰⁾ 仅适用于 IM V5、IM V1、IMV15 以及 IM V18 安装结构型式。无法与选件号 L05 并用；
- ¹¹⁾ 适用于水平安装电机；对于立式安装的电机，请向西门子咨询。电动机安装排水孔时，须在购买电动机时注明其具体安装方式；
- ¹²⁾ 当安装独立风机时，电动机的长度将增加 ΔL 。具体的增加尺寸和技术数据请查看第 8 页内容；
- ¹³⁾ 无风扇和风罩时，电动机的长度将减小 Δl 。按照铭牌上功率数值输出时，电动机必须有外部冷却。客户应当采用正确的冷却方式，没有或错误的冷却方式都将减少电动机的使用寿命，甚至会损坏电动机；
- ¹⁴⁾ SINAMICS变频器联结Omron编码器（E6B2-CWZ6C）时，变频器需要一些特殊配置。详细信息，请咨询西门子热线。
- ¹⁵⁾ SINAMICS变频器可以直接与Omron编码器（E6B2-CWZ1X）联结。
- ¹⁶⁾ 可用于室内、或暴露环境中的的室外安装，也可用于含有中等浓度 SO₂ 的工业环境中，并可用于海洋性气候环境中，但不适用于海上的应用。

- ¹⁾ Order No. supplement Z with option code when ordering;
- ²⁾ Without additional charge
- ³⁾ For FS80 ~ 112 motor, R10 only in combination with Option code H08 (Connection box on NDE) possible.
- ⁴⁾ Cable entry on connection box towards the non-drive end.
- ⁵⁾ For vertical mounting of FS250~FS355 motor, please specially consult with Siemens.
- ⁶⁾ FS280, FS315 and FS355 motor with the regrease device as standard.
- ⁷⁾ For horizontal mounting motor, insulated bearing located at DE; For vertical mounting motor, insulated bearing located at NDE.
- ⁸⁾ Not possible in combination with canopy or separately driven fan (Order code: F70).
- ⁹⁾ Second standard shaft extension on NDE has allowed output from the next smaller frame size.
- ¹⁰⁾ Only applicable for the construction type IM V5, IM V1, IM V15 and IM V18. Not possible in combination with Option code L05.
- ¹¹⁾ Applicable to motor of horizontal mounting. If vertical mounting motor required to be with condensation drainage holes, please inquiry Siemens specially. If condensation drainage holes are required, it is necessary to order the motors in their respective type of construction.
- ¹²⁾ When the separately driven fan is mounted, the length of the motor increase by ΔL . For an explanation of the additional dimension and technical data see from page 8.
- ¹³⁾ Without fan and fan cover, the length of the motor is decrease by Δl . By using the power output of rating plate, the motor must have external cooling by air flow. The correct motor cooling is in responsibility of customer. Missing or wrong cooling reduce the life time or damaged the motor.
- ¹⁴⁾ When SINAMICS inverter is connected with Omron encoder (E6B2-CWZ6C), additional configuration on inverter is needed. For detailed information, please contact with Siemens hotline.
- ¹⁵⁾ Omron encoder (E6B2-CWZ1X) can be directly connected with SINAMICS inverter.
- ¹⁶⁾ Recommended for indoor or outdoor installations exposed to direct weather conditions. Industrial environment with moderate SO₂, inshore maritime climate but not offshore.

外形尺寸 Dimension drawings

1LE0001 铸铁系列电动机 Cast-iron series 1LE0001

机座号从 80M ~ 355M Frame sizes 80M to 355M

IM B3 安装结构型式 Type of construction IM B3

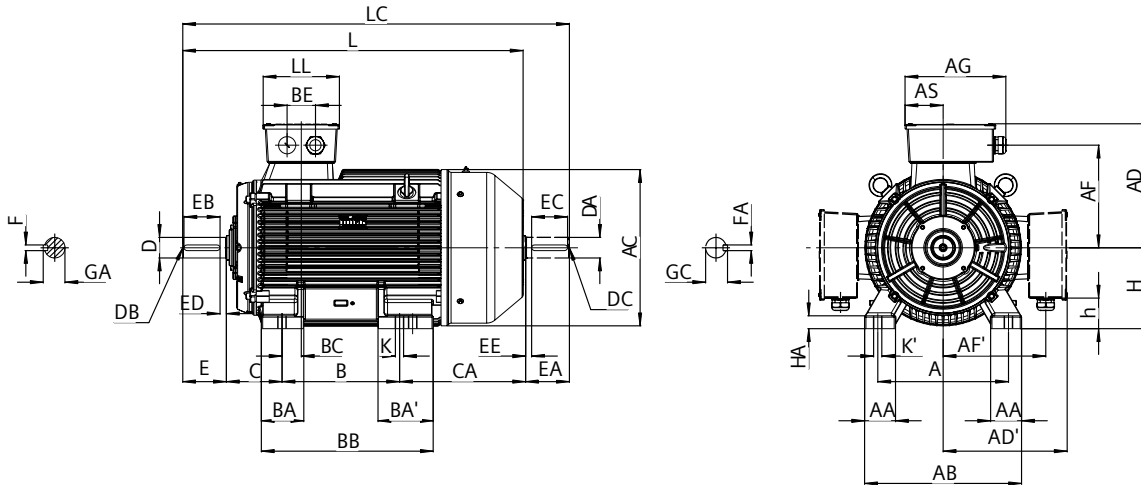

IM B35 安装结构型式 Type of construction IM B35

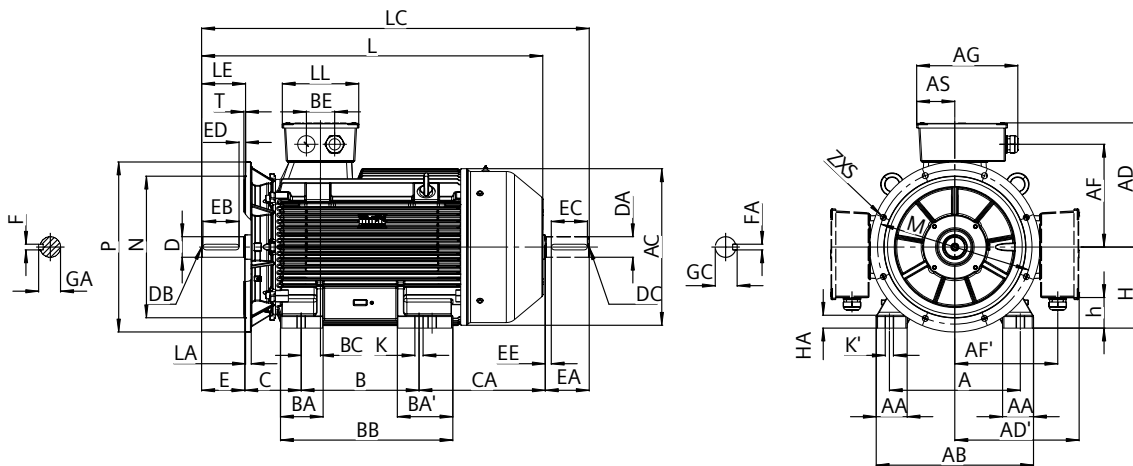

机座号 Frame size	Type 类型 1LE0001-	极数 Poles	尺寸图依据 IEC 标准 Dimension designation according to IEC standards														
			A	AA	AB	AC ¹⁾	AD / AD'	AF / AF'	AG	AH	AS	B ²⁾	BA / BA'	BB	BC	BE	C
80M	OD□2	2	125	36	160	157	142	110.5	145	-	65.5	100	44	135	26	42	50
	OD□2	4, 6	125	36	160	157	142	110.5	145	-	65.5	100	44	135	26	42	50
	OD□3	2, 4, 6	125	36	160	157	142	110.5	145	-	65.5	100	44	135	26	42	50
90S	OE□0	2, 4, 6	140	46	175	175	152	120.5	145	-	65.5	100	46	140	20	42	56
90L	OE□4		140	46	175	175	152	120.5	145	-	65.5	125	46	165	20	42	56
100L	1A□4	2, 4, 6	160	45	200	196	177	140	163	276	70	140	45	176	30.5	54	63/78 ³⁾
	1A□5	4	160	45	200	196	177	140	163	276	70	140	45	176	30.5	54	63/78 ³⁾
112M	1B□2	2, 4, 6	190	45	226	221	188.5	152	163	304	70	140	50	180	22	54	70
132S	1C□0	2, 4, 6, 8	216	50	256	259	212	175	163	354	70	140	64	186	32.5	54	89/104 ³⁾
	1C□1	2	216	50	256	259	212	175	163	354	70	140	64	186	32.5	54	89/104 ³⁾
132M	1C□2	4, 6, 8	216	50	256	259	212	175	163	354	70	178	64	224	32.5	54	89/111 ³⁾
	1C□3	6, 8	216	50	256	259	212	175	163	354	70	178	64	224	32.5	54	89/111 ³⁾

¹⁾ 包含螺栓头的尺寸

²⁾ 该尺寸为 DIN EN 50347 标准所列机座号对应尺寸

³⁾ 仅适用于配置 H08 选件的电机

IM B5 以及 IM V1 安装结构型式 Type of construction IM B5 and IM V1

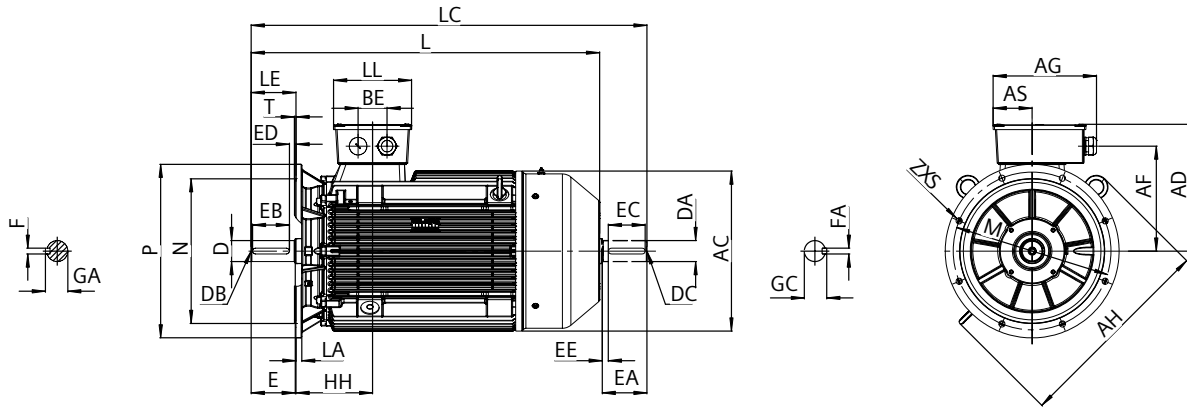

IM B14 安装结构型式 Type of construction IM B14

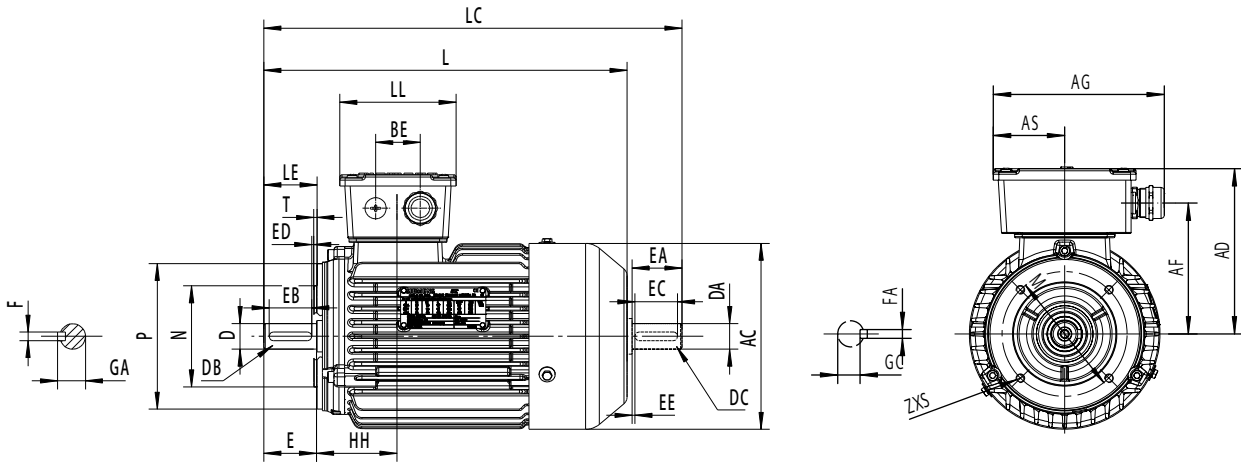

	驱动端轴伸直径 DE shaft extension																非驱动端轴伸 (选项号为 L05) NDE shaft extension (option code L05)						
	CA ²⁾	H	h	HA	HH	K / K'	L	LC	LL	D	DB	E	EB	ED	F	GA	DA	DC	EA	EC	EE	FA	GC
	103	80	14.5	10	76	10	288	323	109	19	M6	40	32	3.5	6	21.5	14	M5	30	22	4	5	16
	103	80	14.5	10	76	10	288	323	109	19	M6	40	32	3.5	6	21.5	14	M5	30	22	4	5	16
	103	80	14.5	10	76	10	288	323	109	19	M6	40	32	3.5	6	21.5	14	M5	30	22	4	5	16
	115	90	24.5	10	76	10	316	361	109	24	M8	50	40	3.5	8	27	19	M6	40	32	5	8	21.5
	115	90	24.5	10	76	10	341	386	109	24	M8	50	40	3.5	8	27	19	M6	40	32	5	8	21.5
	133	100	30	12	93.5	12	390	446	118	28	M10	60	50	3.5	8	31	24	M8	50	40	5	8	27
	133	100	30	12	93.5	12	390	446	118	28	M10	60	50	3.5	8	31	24	M8	50	40	5	8	27
	129.5	112	42	12	92	12	395	450	118	28	M10	60	50	3.5	8	31	24	M8	50	40	5	8	27
	178	132	62	15	121.5	12	480	547	118	38	M12	80	70	4	10	41	28	M10	60	50	5	8	31
	178	132	62	15	121.5	12	480	547	118	38	M12	80	70	4	10	41	28	M10	60	50	5	8	31
	185	132	62	15	121.5	12	525	592	118	38	M12	80	70	4	10	41	28	M10	60	50	5	8	31
	185	132	62	15	121.5	12	525	592	118	38	M12	80	70	4	10	41	28	M10	60	50	5	8	31

¹⁾ Measured across the bolt heads.

²⁾ This dimension is assigned in DIN EN 50347 to the frame size listed.

³⁾ Only for the motor configured with H08 option.

外形尺寸 Dimension drawings

1LE0001 铸铁系列电动机 Cast-iron series 1LE0001

机座号从 80M ~ 355L Frame sizes 80M to 355L

机座号 Frame size	Type 类型 1LE0001-	极数 Poles	尺寸图依据 IEC 标准 Dimension designation according to IEC standards														
			A	AA	AB	AC ¹⁾	AD / AD'	AF / AF'	AG	AH	AS	B ²⁾	BA / BA'	BB	BC	BE	C
160M	1D□2	2, 4, 6, 8	254	60	314	312	255	206	231	422	94	210	70	258	51	68	108/112 ³⁾
	1D□3	2	254	60	314	312	255	206	231	422	94	210	70	258	51	68	108/112 ³⁾
160L	1D□4	2, 4, 6, 8	254	60	314	312	255	206	231	422	94	254	70	302	51	68	108/128 ³⁾
180M	1E□2	2, 4	279	65	339	356	270	221	231	466	94	241	80	301	37	68	121/115 ³⁾
180L	1E□4	4, 6, 8	279	65	339	356	270	221	231	466	94	279	80	339	37	68	121/112 ³⁾
200L	2A□4	2, 4, 6, 8	318	70	378	397	300	247.5	288	532	107.5	305	80	369	69	85	133/123 ³⁾
	2A□5	2,6	318	70	378	397	300	247.5	288	532	107.5	305	80	369	69	85	133/123 ³⁾
225S	2B□0	4	356	80	436	442	327	274	288	556	107.5	286	80	348	63	85	149/136 ³⁾
225M	2B□2	2	356	80	436	442	327	274	288	556	107.5	311	80	373	63	85	149/136 ³⁾
		4, 6, 8															
250M	2C□2	2	406	90	490	488	373	310.5	342	600	123	349	100	421	92	84	168/157 ³⁾
		4, 6, 8															
280S	2D□0	2	457	100	540	538	413	350.5	342	652	123	368	115	454	72	84	190/157 ³⁾
280M	2D□2	4, 6, 8															
		2	457	100	540	538	413	350.5	342	652	123	419	115	505	72	84	190/157 ³⁾
315S	3A□0	4, 6, 8															
		2	508	120	610	608	482	401	401	734	148	406	165	520	75	110	216/180 ³⁾
315M	3A□2	2	508	120	610	608	482	401	401	734	148	457 / 508	165	668	75	110	216/309 ³⁾
315L	3A□5/3A□6/3A□7	4, 6, 8															
		2	508	120	610	608	482	401	401	734	148	457 / 508	165	668	75	110	216/258 ³⁾
355M	3B□2	4, 6, 8															
		2	610	116	726	694	655	572	472	-	175	560 / 630	-	750	-	130	254/378 ³⁾
		4, 6, 8															
355L	3B□3	2	610	116	726	694	655	572	472	-	175	560 / 630	-	750	-	130	254/378 ³⁾
		4, 6, 8															
		6, 8	610	116	726	694	655	572	472	-	175	560 / 630	-	750	-	130	254/308 ³⁾
355L	3B□5	2	610	116	726	694	655	572	472	-	175	560 / 630	-	750	-	130	254/308 ³⁾
		4, 6, 8															
		2	610	116	726	694	655	572	472	-	175	560 / 630	-	750	-	130	254/308 ³⁾
355L	3B□6	4, 6, 8															
		2	610	116	726	694	655	572	472	-	175	560 / 630	-	750	-	130	254/308 ³⁾

¹⁾ 包含螺栓头的尺寸

²⁾ 该尺寸为 DIN EN 50347 标准所列机座号对应尺寸

³⁾ 仅适用于配置 H08 选件的电机

										驱动端轴伸直径 DE shaft extension							非驱动端轴伸 (选项号为 L05) NDE shaft extension (option code L05)						
	CA ²⁾	H	h	HA	HH	K / K'	L	LC	LL	D	DB	E	EB	ED	F	GA	DA	DC	EA	EC	EE	FA	GC
	194	160	66	20	159	15	614	701	158	42	M16	110	100	5	12	45	38	M12	80	70	5	10	41
	194	160	66	20	159	15	614	701	158	42	M16	110	100	5	12	45	38	M12	80	70	5	10	41
	210	160	66	20	159	15	674	761	158	42	M16	110	100	5	12	45	38	M12	80	70	5	10	41
	219	180	86	20	158	15	683	801	158	48	M16	110	100	5	14	51.5	42	M16	110	90	10	12	45
	216	180	86	20	158	15	718	836	158	48	M16	110	100	5	14	51.5	42	M16	110	90	10	12	45
	234	200	64.5	25	202	19	772	892	215	55	M20	110	100	5	16	59	48	M16	110	100	5	14	51.5
	234	200	64.5	25	202	19	772	892	215	55	M20	110	100	5	16	59	48	M16	110	100	5	14	51.5
	255	225	89.5	34	212	19	820	940	215	60	M20	140	125	5	18	64	55	M20	110	100	5	16	59
	255	225	89.5	34	212	19	815	935	215	55	M20	110	100	5	16	59	48	M16	110	100	5	14	51.5
							845	965		60		140	125		18	64	55	M20	110	100	5	16	59
	269	250	81	40	260	24	917	1037	246	60	M20	140	125	5	18	64	55	M20	110	100	5	16	59
								1067		65						69	60	M20	140	125	10	18	64
	237	280	111	40	262	24	976	1126	246	65	M20	140	125	5	18	69	60	M20	140	125	10	18	64
										75				5	20	79.5	65	M20	140	125	10	18	69
	288	280	111	40	262	24	1027	1177	246	65	M20	140	125	5	18	69	60	M20	140	125	10	18	64
										75				20	79.5	65	M20	140	125	10	18	69	
	351	315	111	50	291	28	1113	1265	296	65	M20	140	125	6	18	69	65	M20	140	125	10	18	69
							1143	1295		80		170	140		22	85	75	M20	140	125	10	20	79.5
	480	315	111	50	291	28	1293	1445	296	65	M20	140	125	6	18	69	65	M20	140	125	10	18	69
							1323	1475		80		170			22	85	75	M20	140	125	10	20	79.5
	480	315	111	50	291	28	1293	1445	296	65	M20	140	125	6	18	69	65	M20	140	125	10	18	69
							1323	1475		80		170	140		22	85	75	M20	140	125	10	20	79.5
	536	355	156.5	52	298	28	1490	1642	397	75	M20	140	125	6	20	79.5	65	M20	140	125	10	18	69
							1520	1702		95	M24	170	140		25	100	80	M20	170	140	25	22	85
	536	355	156.5	52	298	28	1490	1642	397	75	M20	140	125	6	20	79.5	65	M20	140	125	10	18	69
							1520	1702		95	M24	170	140		25	100	80	M20	170	140	25	22	85
	536	355	156.5	52	298	28	1520	1702	397	95	M24	170	140	6	25	100	80	M20	170	140	25	22	85
	536	355	156.5	52	298	28	1490	1642	397	75	M20	140	125	6	20	79.5	65	M20	140	125	10	18	69
							1520	1702		95	M24	170	140		25	100	80	M20	170	140	25	22	85
	536	355	156.5	52	298	28	1490	1642	397	75	M20	140	125	6	20	79.5	65	M20	140	125	10	18	69
							1520	1702		95	M24	170	140		25	100	80	M20	170	140	25	22	85

¹⁾ Measured across the bolt heads.
²⁾ This dimension is assigned in DIN EN 50347 to the frame size listed.
³⁾ Only for the motor configured with H08 option.

外形尺寸 Dimension drawings

法兰尺寸 Flange dimension

IM B5、IM B35、IM V1、IM V3 安装结构型式

Type of construction IM B5, IM B35, IM V1, IM V3

IM B14、IM V18、IM V19 安装结构型式

Type of construction IM B14, IM V18, IM V19

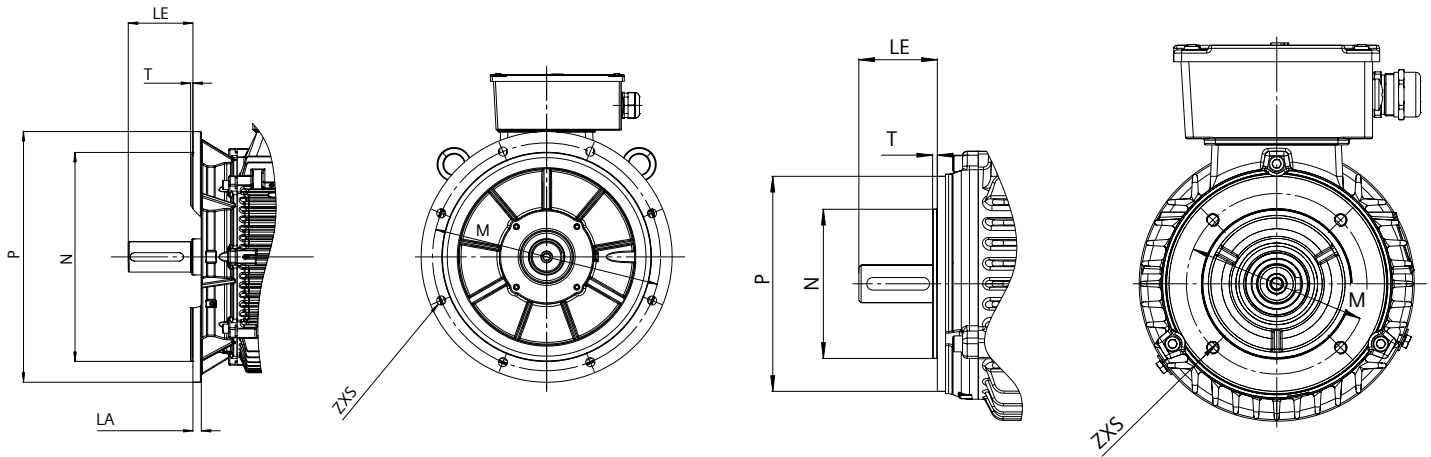

机座号 Frame size	安装结构形式 Type of construction	法兰带通孔 (FF/A) / 带内螺纹孔 (FT/C) Flange with through holes (FF/A) / tapped holes (FT/C)	尺寸图依据 IEC 标准 Dimension designation according to IEC standards							
		按照 DIN EN 50347 标准 According to DIN EN 50347	LA	LE	M	N	P	S	T	Z
80	IM B5, IM B35, IM V1, IM V3 IM B14, IM V18, IM V19	FF 165	10	40	165	130	200	12	3.5	4
		FT 100	—	40	100	80	120	M 6	3	4
90	IM B5, IM B35, IM V1, IM V3 IM B14, IM V18, IM V19	FF 165	10	50	165	130	200	12	3.5	4
		FT 115	—	50	115	95	140	M 8	3	4
100	IM B5, IM B35, IM V1, IM V3 IM B14, IM V18, IM V19	FF 215	11	60	215	180	250	14.5	4	4
		FT 130	—	60	130	110	160	M 8	3.5	4
112	IM B5, IM B35, IM V1, IM V3 IM B14, IM V18, IM V19	FF 215	11	60	215	180	250	14.5	4	4
		FT 130	—	60	130	110	160	M 8	3.5	4
132	IM B5, IM B35, IM V1, IM V3 IM B14, IM V18, IM V19	FF 265	14	80	265	230	300	14.5	4	4
		FT 165	—	80	165	130	200	M 10	3.5	4
160	IM B5, IM B35, IM V1, IM V3 IM B14, IM V18, IM V19	FF 300	14	110	300	250	350	18.5	5	4
		FT 215	—	110	215	180	250	M 12	4	4
180	IM B5, IM B35, IM V1, IM V3	FF 300	16	110	300	250	350	18.5	5	4
200	IM B5, IM B35, IM V1, IM V3	FF 350	16	110	350	300	400	18.5	5	4
225	IM B5, IM B35, IM V1, IM V3	FF 400	16	110/140	400	350	450	18.5	5	8
250	IM B5, IM B35, IM V1, IM V3	FF 500	18	140	500	450	550	18.5	5	8
280	IM B5, IM B35, IM V1, IM V3	FF 500	18	140	500	450	550	18.5	5	8
315	IM B5, IM B35, IM V1, IM V3	FF 600	22	140/170	600	550	660	24	6	8
355	IM B35, IM V1	FF 740	22	140/170	740	680	800	24	6	8

认证 Certificates



北方区

北京
北京市朝阳区望京中环南路7号
电话: (010) 6476 8888

包头
内蒙古自治区包头市昆区钢铁大街74号
财富中心1905室
电话: (0472) 520 8828

济南
山东省济南市舜耕路28号
舜耕山庄商务会所5层
电话: (0531) 8266 6088

青岛
山东省青岛市香港中路76号
颐中假日酒店4楼
电话: (0532) 8573 5888

烟台
山东省烟台市南大街9号
金都大厦16层1606室
电话: (0535) 212 1880

淄博
山东省淄博市张店区中心路177号
淄博饭店7层
电话: (0533) 218 7877

潍坊
山东省潍坊市奎文区四平路31号
鸢飞大酒店1507房间
电话: (0536) 822 1866

济宁
山东省济宁市高新区火炬路19号
香港大厦361房间
电话: (0537) 239 6000

天津
天津市和平区南京路189号
津汇广场写字楼1401室
电话: (022) 8319 1666

唐山
河北省唐山市建设北路99号
火炬大厦1308室
电话: (0315) 317 9450/51

石家庄
河北省石家庄市中山路303号
世贸广场酒店1309号
电话: (0311) 8669 5100

太原
山西省太原市府西街69号
国际贸易中心西塔16层1609B-1610室
电话: (0351) 868 9048

呼和浩特
内蒙古呼和浩特市乌兰察布西路
内蒙古饭店10层1022室
电话: (0471) 620 4133

东北区

沈阳
辽宁省沈阳市沈河区北站路59号
财富大厦E座12-14层
电话: (024) 8251 8111

大连
辽宁省大连市高新园区
七贤岭广贤路117号
电话: (0411) 8369 9760

长春
吉林省长春市亚泰大街3218号
通钢国际大厦22层
电话: (0431) 8898 1100

哈尔滨
黑龙江省哈尔滨市南岗区红军街15号
奥威斯发展大厦30层A座
电话: (0451) 5300 9933

华西区

成都
四川省成都市高新区拓新东街81号
天府软件园C6栋1/2楼
电话: (028) 6238 7888

重庆
重庆市渝中区邹容路68号
大都会商厦18层1807-1811
电话: (023) 6382 8919

贵阳
贵州省贵阳市南明区花果园后街
彭家湾E7栋(国际金融街1号)
14楼01&02房
电话: (0851) 551 0310

昆明
云南昆明市北京路155号
红塔大厦1204室
电话: (0871) 6315 8080

西安
西安市高新区锦业一路11号
西安国家服务外包示范基地一区D座3层
电话: (029) 8831 9898

乌鲁木齐
新疆乌鲁木齐市五一一路160号
新疆鸿福大饭店贵宾楼918室
电话: (0991) 582 1122

银川
银川市北京东路123号
太阳神大酒店A区1507房间
电话: (0951) 786 9866

兰州
甘肃省兰州市东岗西路589号
锦江阳光酒店2206室
电话: (0931) 888 5151

华东区

上海
上海杨浦区大连路500号
西门于上海中心
电话: (021) 3889 3889

杭州
浙江省杭州市西湖区杭大路15号
嘉华国际商务中心1505室
电话: (0571) 8765 2999

宁波
浙江省宁波市江东区沧海路1926号
上东国际2号楼2511室
电话: (0574) 8785 5377

绍兴
浙江省绍兴市解放北路
玛格丽特商业中心西区2幢
玛格丽特酒店10层1020室
电话: (0575) 8820 1306

温州
浙江省温州市车站大道
高联大厦9层B1室
电话: (0577) 8606 7091

南京
江苏省南京市中山路228号
地铁大厦17层
电话: (025) 8456 0550

扬州
扬州市文昌西路56号
公元国际大厦809室
电话: (0514) 8789 4566

扬中
江苏省扬中市前进北路52号
扬中宾馆明珠楼318室
电话: (0511) 8832 7566

徐州
江苏省徐州市泉山区中山北路29号
国贸大厦7A7室
电话: (0516) 8370 8388

苏州
江苏省苏州市新加坡工业园苏华路2号
国际大厦11层17-19单元
电话: (0512) 6288 8191

无锡
江苏省无锡市县前东街1号
金陵大酒店2401-2402室
电话: (0510) 8273 6868

南通
江苏省南通市崇川区桃园路8号
中南世纪城17栋1104室
电话: (0513) 8102 9880

常州
江苏省常州市关河东路38号
九洲寰宇大厦911室
电话: (0519) 8989 5801

盐城
江苏省盐城市盐都区
华邦国际大厦A区2008室
电话: (0515) 8836 2680

昆山
江苏省昆山市伟业路18号
昆山现代广场A座1019室
电话: (0512) 55118321

华南区

广州
广东省广州市天河路208号
天河城侧粤海天河城大厦8-10层
电话: (020) 3718 2222

佛山
广东省佛山市汾江中路121号
东建大厦19楼K单元
电话: (0757) 8232 6710

珠海
广东省珠海市景山路193号
珠海石景山旅游中心229房间
电话: (0756) 337 0869

南宁
广西省南宁市金湖路63号
金源现代城9层935室
电话: (0771) 552 0700

深圳
广东省深圳市南山区华侨城
汉唐大厦9楼
电话: (0755) 2693 5188

东莞
广东省东莞市南城区宏远路1号
宏远大厦1510室
电话: (0769) 2240 9881

汕头
广东省汕头市金砂路96号
金海湾大酒店19楼1920室
电话: (0754) 8848 1196

海口
海南省海口市滨海大道69号
宝华海景大酒店803房
电话: (0898) 6678 8038

福州
福建省福州市五四路89号
置地广场11层04、05单元
电话: (0591) 8750 0888

厦门
福建省厦门市厦禾路189号
银行中心21层2111-2112室
电话: (0592) 268 5508

华中区

武汉
湖北省武汉市汉口建设大道709号
建设银行大厦20楼
电话: (027) 8548 6688

合肥
安徽省合肥市淮滨路278号
财富广场首座27层2701-2702室
电话: (0551) 6568 1299

宜昌
湖北省宜昌市东山大道95号
清江大厦2011室
电话: (0717) 631 9033

长沙
湖南省长沙市五一大道456号
亚大时代写字楼2101、2101-2室
电话: (0731) 8446 7770

南昌
江西省南昌市北京西路88号
江信国际大厦14楼1403/1405室
电话: (0791) 8630 4866

郑州
河南省郑州市中原区中原中路220号
裕达国贸中心写字楼2506房间
电话: (0371) 6771 9110

洛阳
河南省洛阳市涧西区西苑路6号
友谊宾馆516室
电话: (0379) 6468 3519

技术培训
北京: (010) 6476 8958
上海: (021) 6281 5933-305/307/308
广州: (020) 3810 2015
武汉: (027) 8548 6688-6400
沈阳: (024) 2294 9880/8251 8219
重庆: (023) 6382 8919-3002

技术资料
北京: (010) 6476 3726
技术支持与服务热线
电话: 400 810 4288
(010) 6471 9990
传真: (010) 6471 9991
E-mail: 4008104288.cn@siemens.com
Web: www.4008104288.com.cn

亚太技术支持 (英文服务)
及软件授权维修热线
电话: (010) 6475 7575
传真: (010) 6474 7474
Email: support.asia.automation@siemens.com

直接扫描
获得本书
PDF文件



更多信息
请访问



西门子(中国)有限公司
工业业务领域
驱动技术集团

如有变动, 恕不事先通知
订货号: E20001-K0369-C600-V2-5D00
666-SH902627-081410

西门子公司版权所有

本宣传册中提供的信息只是对产品的一般说明和特性介绍。文中内容可能与实际应用的情况有所出入, 并且可能会随着产品的进一步开发而发生变化。仅当相关合同条款中有明确规定时, 西门子方有责任提供文中所述的产品特性。

宣传册中涉及的所有名称可能是西门子公司或其供应商的商标或产品名称, 如果第三方擅自使用, 可能会侵犯所有者的权利。